

AIRDROP OF SUPPLIES AND EQUIPMENT:

RIGGING HEAVY ANTITANK ASSAULT WEAPON SYSTEM (TOW)



DISTRIBUTION RESTRICTION: Approved for public release; distribution is unlimited.

**HEADQUARTERS
DEPARTMENT OF THE ARMY
DEPARTMENT OF THE AIR FORCE**

AIRDROP OF SUPPLIES AND EQUIPMENT: RIGGING HEAVY ANTITANK ASSAULT WEAPON SYSTEM (TOW)

CONTENTS

	Page
PREFACE	iv
CHAPTER 1 INTRODUCTION	
Description of Items	1-1
Special Considerations	1-1
CHAPTER 2 RIGGING TOW WEAPON SYSTEMS AND MISSILES IN A-22 CARGO BAGS	
Section - I Rigging TOW Weapon System and Missiles in an A-22 Cargo Bag	
Description of Load	2-1
Rigging A-22 Cargo Bags	2-1
Attaching Cargo Parachutes	2-1
Marking the Rigged Load	2-9
Equipment Required	2-10
Section - II Rigging 12 TOW Missiles in an A-22 Cargo Bag for Low-velocity Airdrop	
Description of Load	2-11
Rigging A-22 Cargo Bag	2-11
Attaching Cargo Parachutes	2-11
Marking the Rigged Load	2-14
Equipment Required	2-14

DISTRIBUTION RESTRICTION: Approved for public release; distribution is unlimited.

* This publication supercedes FM 10-529/TO 13C7-10-171, 16 October, 1986

	Page
Section - III Rigging 12 Missile Overpacks in an A-22 Cargo Bag for High-velocity Airdrop	
Description of Load	2-15
Rigging A-22 Cargo Bag	2-15
Attaching Cargo Parachutes	2-15
Marking the Rigged Load	2-19
Equipment Required	2-20
CHAPTER 3 RIGGING TOW MISSILES IN 1/4-TON CARGO TRAILER FOR LOW-VELOCITY AIRDROP	
Description of Load	3-1
Preparing Platform	3-1
Stowing Accompanying Load	3-3
Placing Honeycomb Stacks and Placing the Trailer	3-8
Lashing Trailer	3-9
Installing Suspension Slings	3-10
Installing Cargo Parachutes and Release Assembly	3-11
Installing Extraction System	3-12
Installing Extraction Parachute	3-13
Installing Provisions for Emergency Restraints	3-13
Marking Rigged Load	3-13
Equipment Required	3-13
CHAPTER 4 RIGGING TOW MISSILES IN BOXES ON TYPE V PLATFORM FOR LOW-VELOCITY AIRDROP	
Section - I Rigging Missiles in A-22 Cargo Bags on a Type V Platform for Low-velocity Airdrop	
Description of Load	4-1
Preparing Platform	4-1
Building and Placing Honeycomb Stacks	4-3
Placing Missiles in A-22 Cargo Bags	4-4
Placing Missiles in A-22 Cargo Bags on Platform	4-7
Lashing Load	4-8
Installing Suspension Slings	4-10
Installing Cargo Parachutes	4-11
Installing Release System	4-12
Installing Extraction System	4-13
Installing Extraction Parachute	4-14
Installing Provisions for Emergency Restraints	4-14
Marking Rigged Load	4-14
Equipment Required	4-14
Section - II Rigging Missiles on a Type V Platform for Low-velocity Airdrop	
Description of Load	4-18
Preparing Platform	4-18
Building and Placing Honeycomb Stacks	4-20
Placing Missile Boxes on Platform	4-21

Lashing Load	4-26
Installing Suspension Slings	4-30
Installing Cargo Parachutes	4-31
Installing Release System	4-32
Installing Extraction System	4-33
Installing Extraction Parachute	4-33
Installing Provisions for Emergency Restraints	4-33
Marking Rigged Load	4-33
Equipment Required	4-33

CHAPTER 5 RIGGING IMPROVED TOW AIMING SYSTEM (ITAS) IN M1121 HMMWV TRUCK FOR LOW-VELOCITY AIRDROP

Description of Load	5-1
Preparing Platform, Honeycomb, and Truck	5-1
Rigging ITAS in HMMWV Truck	5-1
Completing the Load	5-1

CHAPTER 6 RIGGING M966, M1036, AND M1121 TOW CARRIERS FOR LOW-VELOCITY AIRDROP ON A TYPE V PLATFORM

Description of Load	6-1
Preparing Platform	6-1
Preparing and Positioning Honeycomb Stacks	6-2
Preparing Truck	6-2
Stowing Accompanying Load and Securing Doors	6-2
Lifting and Positioning Truck and Installing Drive-off Aids	6-9
Lashing Truck	6-9
Installing and Safeying Suspension Slings	6-9
Stowing Cargo Parachutes	6-9
Installing Parachute Release	6-9
Installing Extraction System	6-9
Installing Provisions for Emergency Restraints	6-9
Placing Extraction Parachute	6-9
Marking Rigged Load	6-10
Equipment Required	6-10

Glossary	glossary 1
----------------	------------

References	references 1
------------------	--------------

PREFACE

SCOPE

This manual tells and shows how to rig TOW weapon systems and missiles. The TOW can be low-velocity airdropped from C5, C-17, C-130, and C-141 aircraft.

USER INFORMATION

The proponent of this publication is HQ TRADOC. You are encouraged to report any errors or omissions and to suggest ways of making this a better manual.

Army personnel, send your comments on DA Form 2028 directly to:

Director
Aerial Delivery and Field Services Department
USA Quartermaster Center and School
1010 Shop Road
Fort Lee, Virginia 23801-1502

Air Force personnel, send your reports on AFTO Form 22 through:

Headquarters
Air Mobility Command (AMC/DOKT)
402 Scott Drive, Unit 3AI
Scott AFB, Illinois 62225-5302

Air Force personnel in Special Operations Command, send your reports on AFTO Form 22 through:

HQ AFSOC/DOXT
100 Bartley Street, Suite 260
Hurlburt Field, FL 32544-5273

to:

Director
Aerial Delivery and Field Services Department
USA Quartermaster Center and School
1010 Shop Road
Fort Lee, Virginia 23801-1502

Also send an information copy of AFTO Form 22 to:

SA-ALC/TILD
485 Quentin Roosevelt Road
Kelly AFB, Texas 78241-5000

Chapter 1

Introduction

DESCRIPTION OF ITEMS

- 1-1. The description of the items covered in this manual is given below:
- A TOW missile in its overpack weighs 87 pounds. Its length is 57 1/2 inches, its width is 12 inches, and its height is 12 inches. TOW missiles are rigged in overpacks in A-22 containers in three configurations, in the M416, 1/4-ton trailer, and on type V platforms.
 - The M416, 1/4-ton trailer with seven encased missiles weighs 1, 170 pounds. It is 109 inches long, 61 inches wide, and 44 inches high.
 - The M966 HMMWV-series truck with six TOW missiles, the launcher, traversing unit, and guidance system weighs 8, 810 pounds. It is 180 inches long, 85 inches wide, and is 69 inches high in reduced configuration.
 - The Improved TOW Aiming System (ITAS) can be substituted for the guidance system mentioned above in the M966 or M1121 truck. It weighs ____ pounds and consists of the traversing unit, battery power source, fire control subsystem, and target acquisition unit subsystem.

SPECIAL CONSIDERATIONS

- 1-2. Special considerations for this manual are described below.
- The loads covered in this manual may include hazardous materials as defined in AFJMAN 24-204/TM 38-250. If included, the hazardous materials must be packaged, marked, and labeled as required by AFJMAN 24-204/TM 38-250.
 - Be sure that a vehicle rigged using these procedures is the same vehicle shown and described in this manual. Be sure that any equipment rigged inside the vehicle is restrained and protected.
 - A copy of this manual must be available to the joint airdrop inspectors during the before- and after-loading inspections.

Chapter 2

Rigging TOW Weapon Systems and Missiles in A-22 Cargo Bags

SECTION I- RIGGING TOW WEAPON SYSTEM AND MISSILES IN AN A-22 CARGO BAG FOR LOW-VELOCITY AIRDROP

DESCRIPTION OF LOAD

2-1. The TOW weapon system consists of the launcher, launch tube, and power pack. It can be rigged with eight missiles in an A-22 cargo bag for low-velocity airdrop. The load requires one G-12E or three G-14 cargo parachutes.

RIGGING A-22 CARGO BAG

2-2. Rig the TOW weapon system and eight missiles in the A-22 cargo bag as described below.

- a. Prepare the skid board as shown in Figures 2-1 and 2-2.
- b. Lay out the A-22 cargo bag as shown in Figure 2-3.
- c. Pack the TOW weapon system and missiles as shown in Figures 2-4 through 2-7.

ATTACHING CARGO PARACHUTES

2-3. Prepare and install one G-12E cargo parachute or three G-14 cargo parachutes to the A-22 cargo bag according to FM 10-500-3/TO 13C7-1-11, and as shown in Figure 2-8.

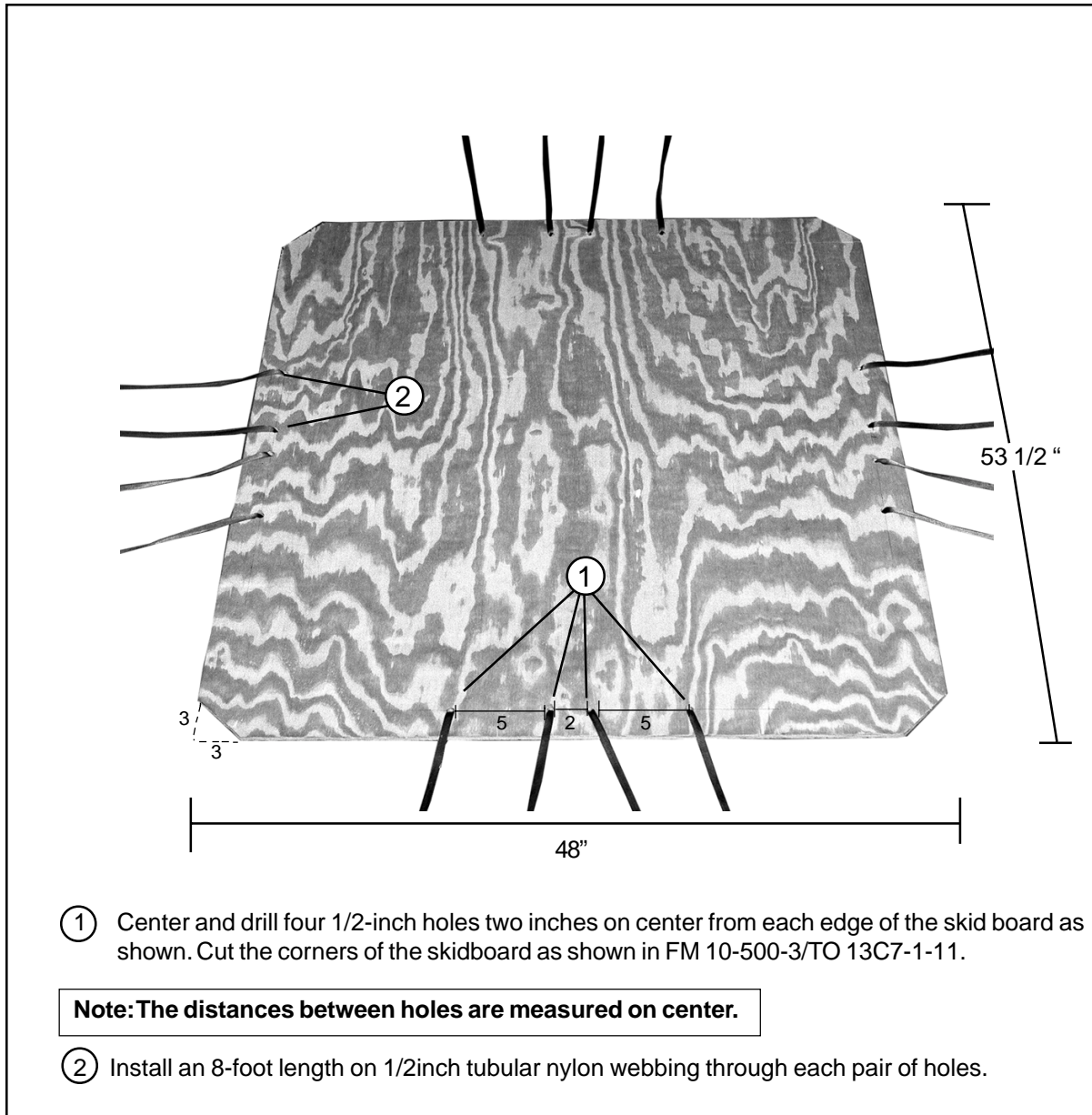

- ① Center and drill four 1/2-inch holes two inches on center from each edge of the skid board as shown. Cut the corners of the skidboard as shown in FM 10-500-3/TO 13C7-1-11.

Note: The distances between holes are measured on center.

- ② Install an 8-foot length on 1/2inch tubular nylon webbing through each pair of holes.

Figure 2-1. Skid Prepared

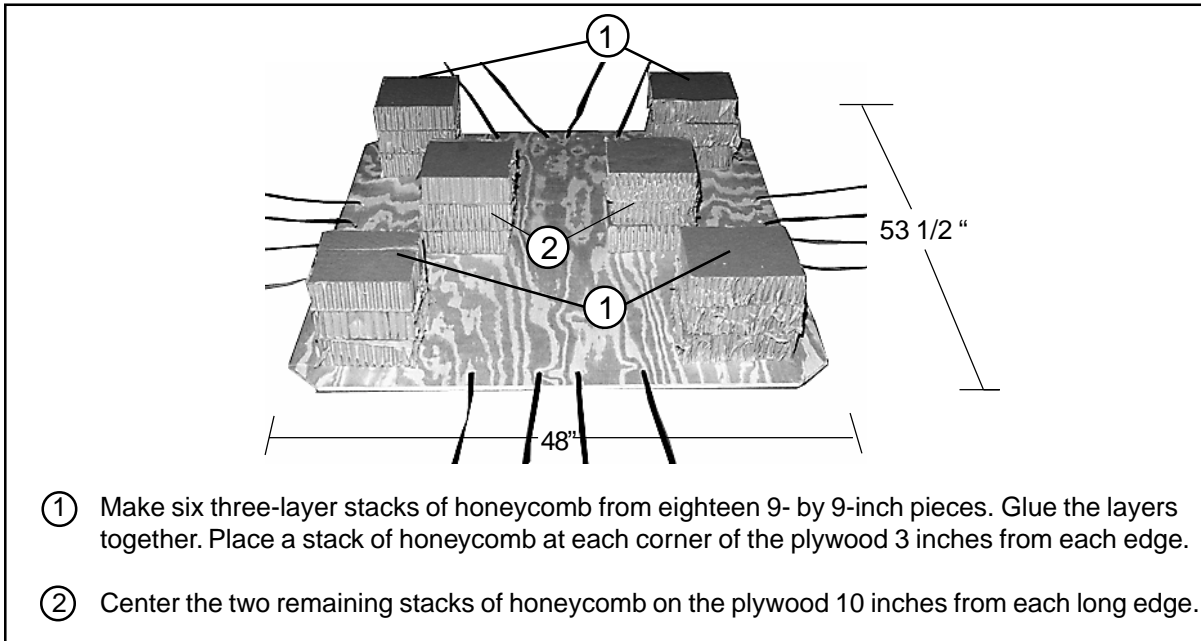

- ① Make six three-layer stacks of honeycomb from eighteen 9- by 9-inch pieces. Glue the layers together. Place a stack of honeycomb at each corner of the plywood 3 inches from each edge.
- ② Center the two remaining stacks of honeycomb on the plywood 10 inches from each long edge.

Figure 2-2. Honeycomb Positioned on the Skid

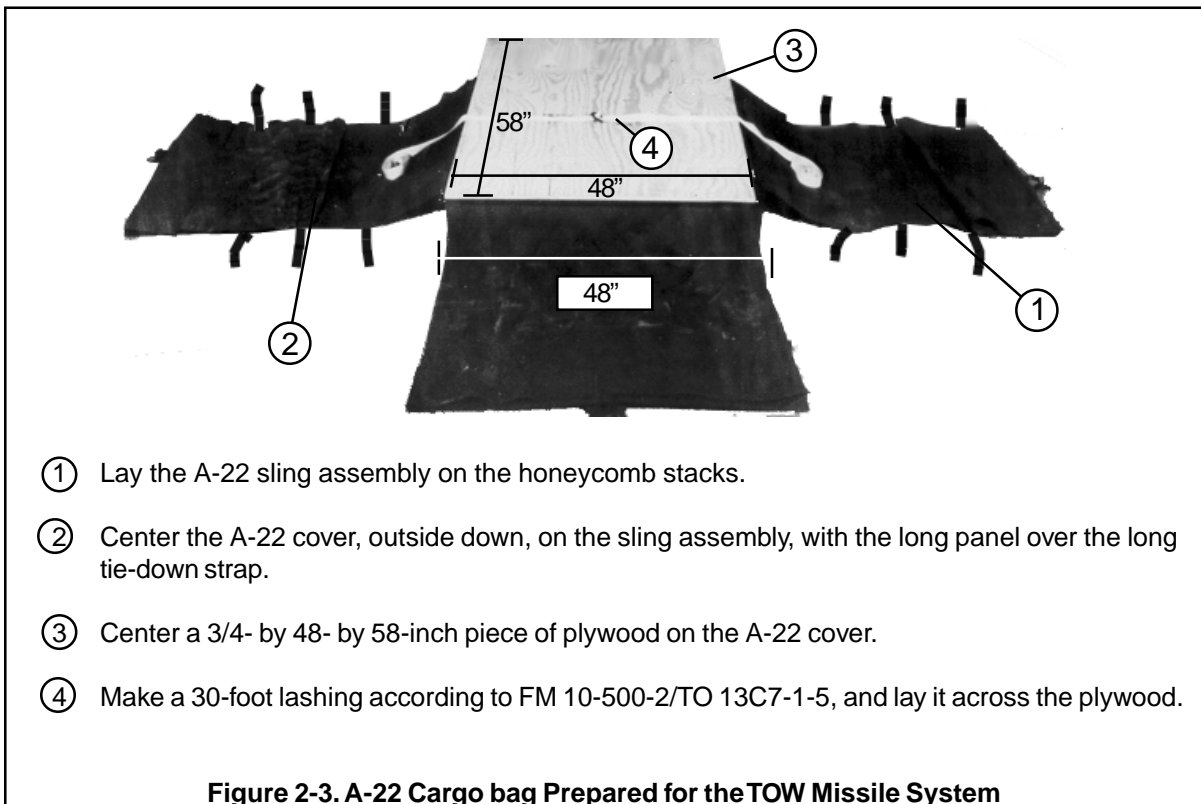

- ① Lay the A-22 sling assembly on the honeycomb stacks.
- ② Center the A-22 cover, outside down, on the sling assembly, with the long panel over the long tie-down strap.
- ③ Center a 3/4- by 48- by 58-inch piece of plywood on the A-22 cover.
- ④ Make a 30-foot lashing according to FM 10-500-2/TO 13C7-1-5, and lay it across the plywood.

Figure 2-3. A-22 Cargo bag Prepared for the TOW Missile System

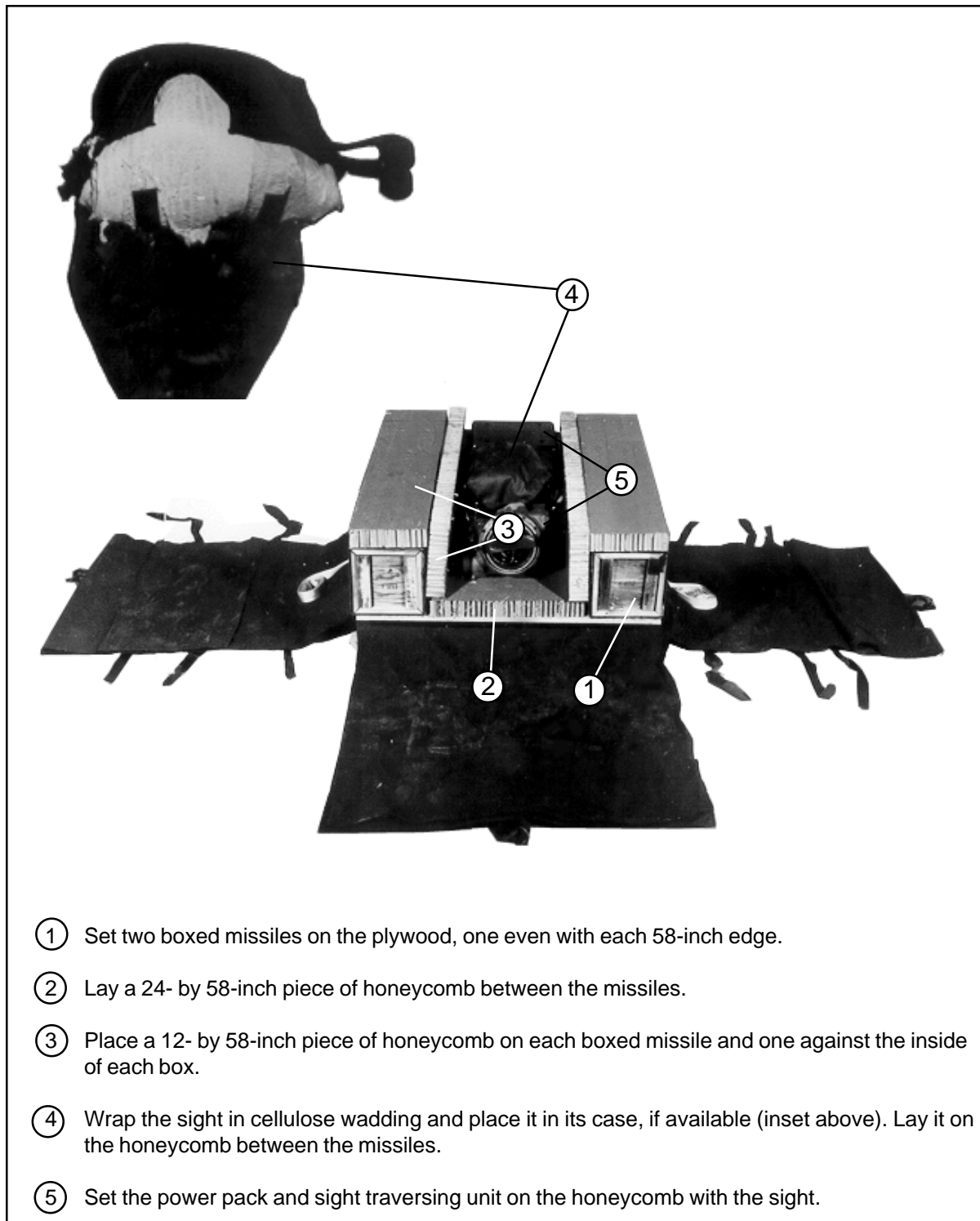

- ① Set two boxed missiles on the plywood, one even with each 58-inch edge.
- ② Lay a 24- by 58-inch piece of honeycomb between the missiles.
- ③ Place a 12- by 58-inch piece of honeycomb on each boxed missile and one against the inside of each box.
- ④ Wrap the sight in cellulose wadding and place it in its case, if available (inset above). Lay it on the honeycomb between the missiles.
- ⑤ Set the power pack and sight traversing unit on the honeycomb with the sight.

Figure 2-4. Missiles, Sight Traversing Unit, Sight, and Power Pack Stowed

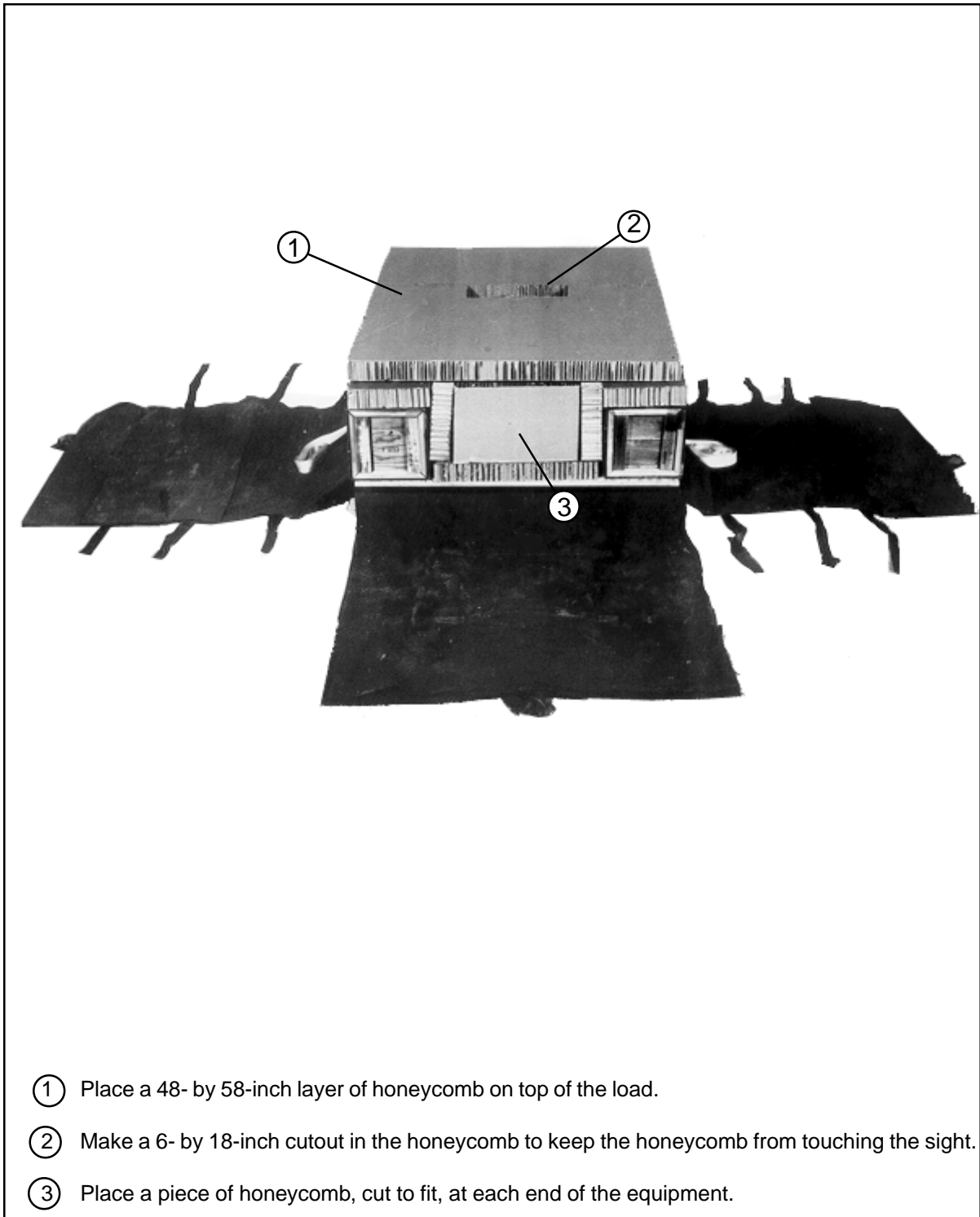

Figure 2-5. Honeycomb Placed on Top of the Load

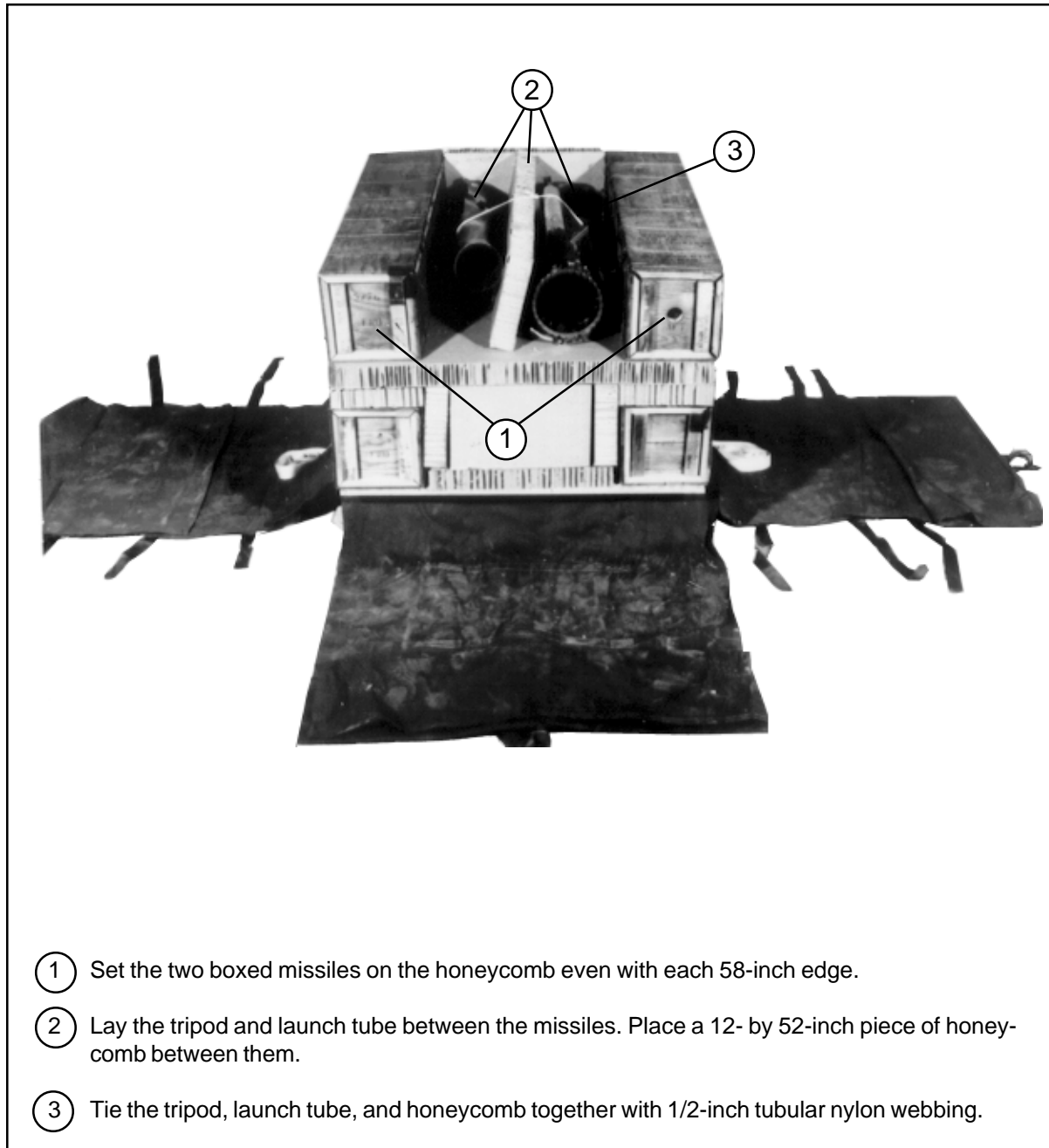

Figure 2-6. Missiles, Tripod, and Launch Tube Stowed

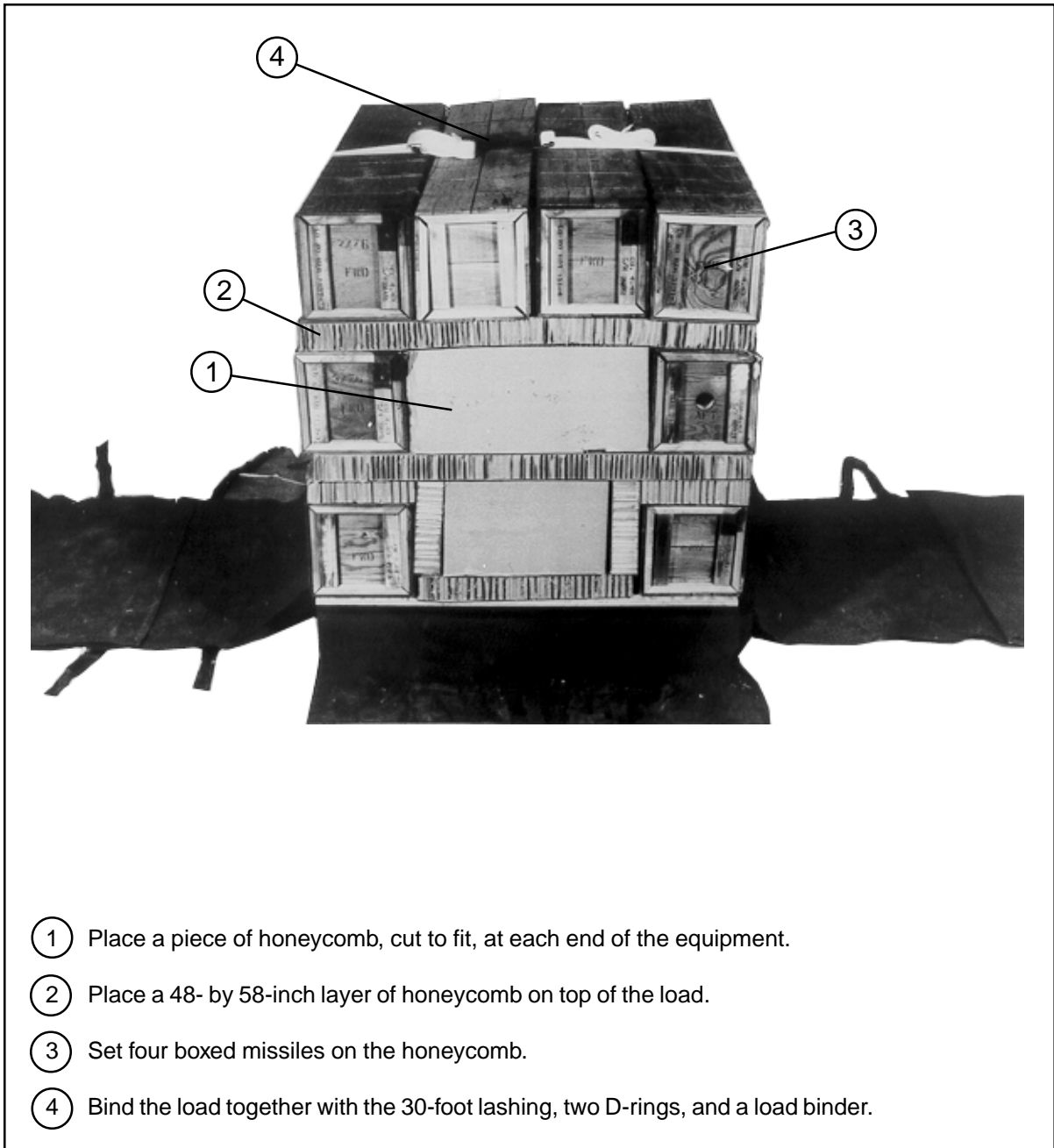
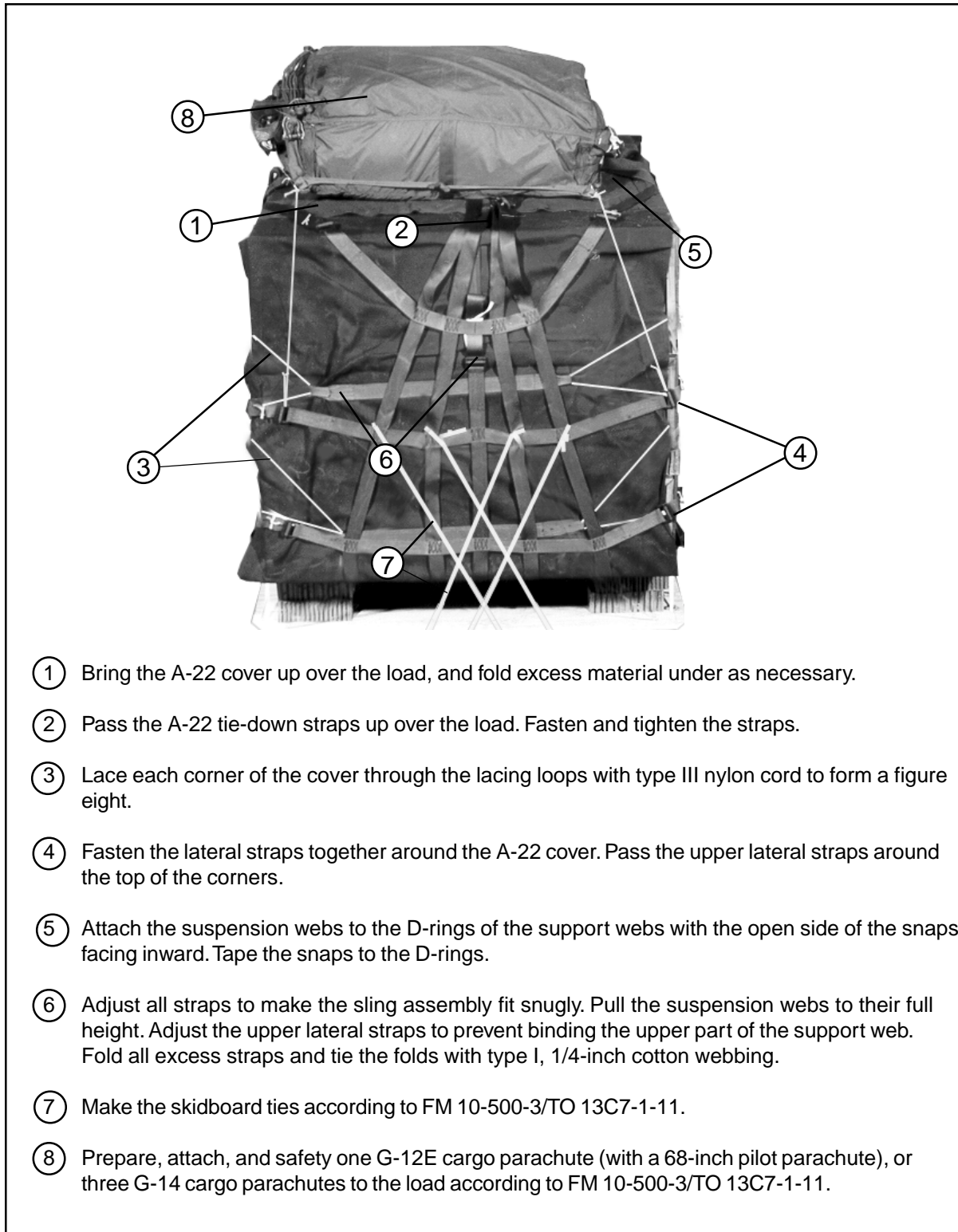

Figure 2-7. Load Completed and Bound Together



- ① Bring the A-22 cover up over the load, and fold excess material under as necessary.
- ② Pass the A-22 tie-down straps up over the load. Fasten and tighten the straps.
- ③ Lace each corner of the cover through the lacing loops with type III nylon cord to form a figure eight.
- ④ Fasten the lateral straps together around the A-22 cover. Pass the upper lateral straps around the top of the corners.
- ⑤ Attach the suspension webs to the D-rings of the support webs with the open side of the snaps facing inward. Tape the snaps to the D-rings.
- ⑥ Adjust all straps to make the sling assembly fit snugly. Pull the suspension webs to their full height. Adjust the upper lateral straps to prevent binding the upper part of the support web. Fold all excess straps and tie the folds with type I, 1/4-inch cotton webbing.
- ⑦ Make the skidboard ties according to FM 10-500-3/TO 13C7-1-11.
- ⑧ Prepare, attach, and safety one G-12E cargo parachute (with a 68-inch pilot parachute), or three G-14 cargo parachutes to the load according to FM 10-500-3/TO 13C7-1-11.

Figure 2-8. A-22 Cargo Bag Secured and Parachutes Installed

MARKING THE RIGGED LOAD

2-4. Mark the rigged load as described in Chapter 1, FM 10-500-3/TO 13C7-1-11, using the data given in Figure 2-9. Complete the Shipper's Declaration for Dangerous Goods.

CAUTION
Make the final inspection required by Chapter 1, FM 10-500-3/TO 13C7-1-11 before the load leaves the rigging site.



RIGGED LOAD DATA

Weight.....	1,217 pounds
Width.....	48 inches
Height.....	72 inches
Length.....	58 inches

Figure 2-9. TOW Weapon System and Missiles Rigged in an A-22 Cargo Bag for Low-velocity Airdrop

EQUIPMENT REQUIRED

2-5. The equipment required to rig this load is listed in Table 2-1.

Table 2-1. Equipment Required to Rig the TOW Weapon System and Eight Missiles in A-22 Cargo Bag

National Stock Number	Item	Quantity
8040-00-273-8713	Adhesive, paste, 1-gal	As required
1670-00-587-3421	Bag, cargo, aerial delivery, A-22	1
4020-00-240-2146	Cord, nylon, type III, 550-lb	As required
1670-00-753-3928	Pad, energy-dissipating, honeycomb	3 sheets
1670-01-065-3751	Parachute, cargo, 64-ft diam, G-12E or	1
1670-00-999-2658	Parachute, cargo, G-14	3
1670-00-216-7297	Parachute, pilot, 68-in diam	1
5530-00-914-5118	Plywood, 1-in thick 48- by 53 1/2-in 48- by 58-in	1
7510-00-266-5016	Tape, adhesive, 2-in	As required
8310-00-917-3945	Thread, cotton, ticket number 8/7 (ticket nr 5)	As required
1670-00-937-0271	Tie-down assembly, 15-ft	2
8305-00-268-2411	Webbing, type I, cotton, 1/4-in	As required
8305-00-082-5752	Webbing, nylon, tubular, 1/2-in	As required

SECTION II - RIGGING 12 TOW MISSILES IN AN A-22 CARGO BAG FOR LOW-VELOCITY AIRDROP

DESCRIPTION OF LOAD

2-6. This load consists of 12 TOW missiles in overpacks. The 12 missiles are rigged in a standard A-22 cargo bag. The load requires one G-12E or three G-14 cargo parachutes.

RIGGING A-22 CARGO BAG

- 2-7. Rig 12 TOW missiles in the A-22 cargo bag as described below.
- a. Prepare the skid board and A-22 cargo bag as shown in Figures 2-1 and 2-2 of Section I.
 - b. Pack the missiles as shown in Figure 2-10.
 - c. Close and secure the A-22 cargo bag as shown in Figure 2-11.

ATTACHING CARGO PARACHUTES

2-8. Prepare and attach one G-12E cargo parachute or three G-14 cargo parachutes as shown in Figure 2-11, and according to FM 10-500-3/TO 13C7-1-11.

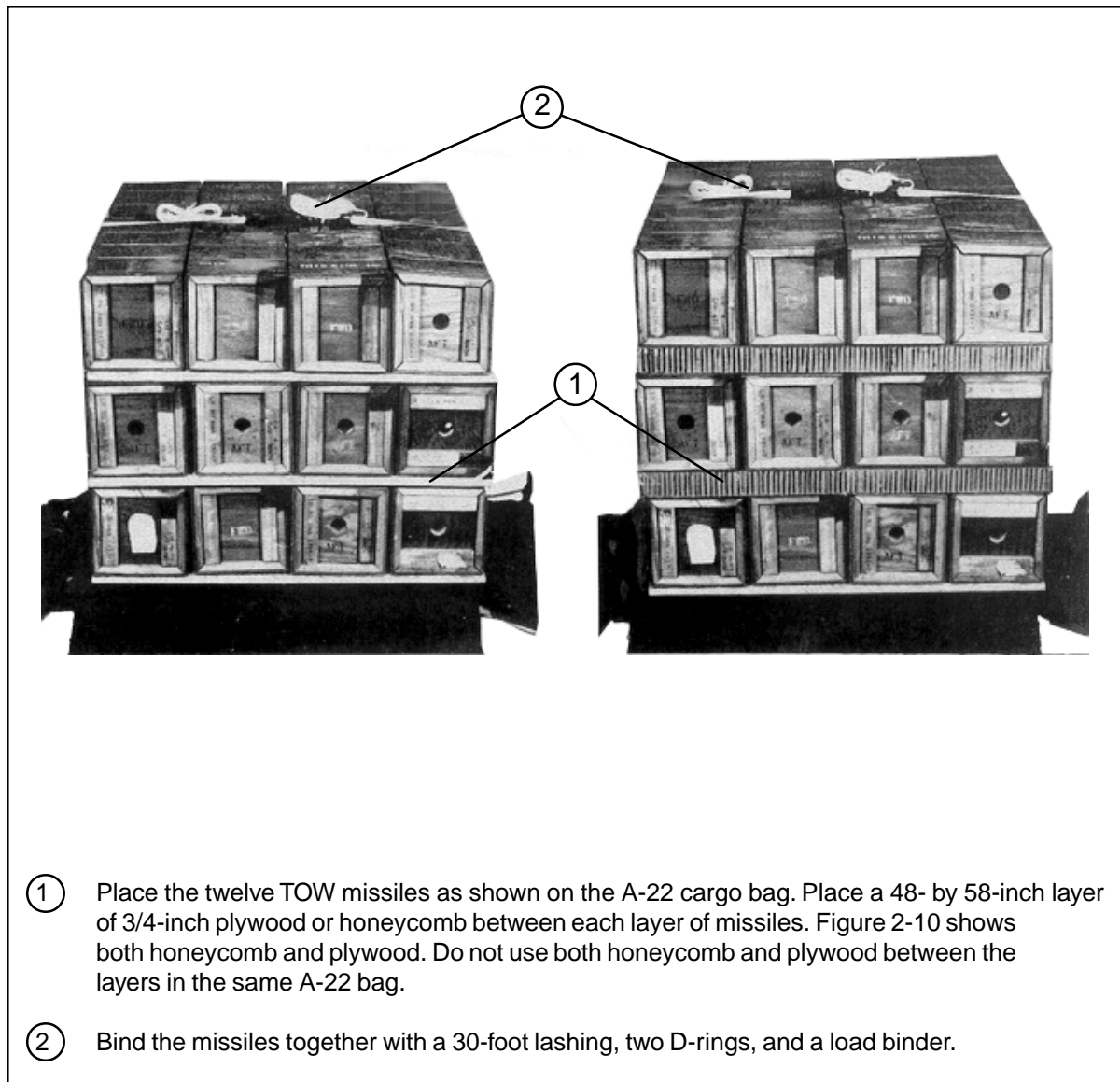
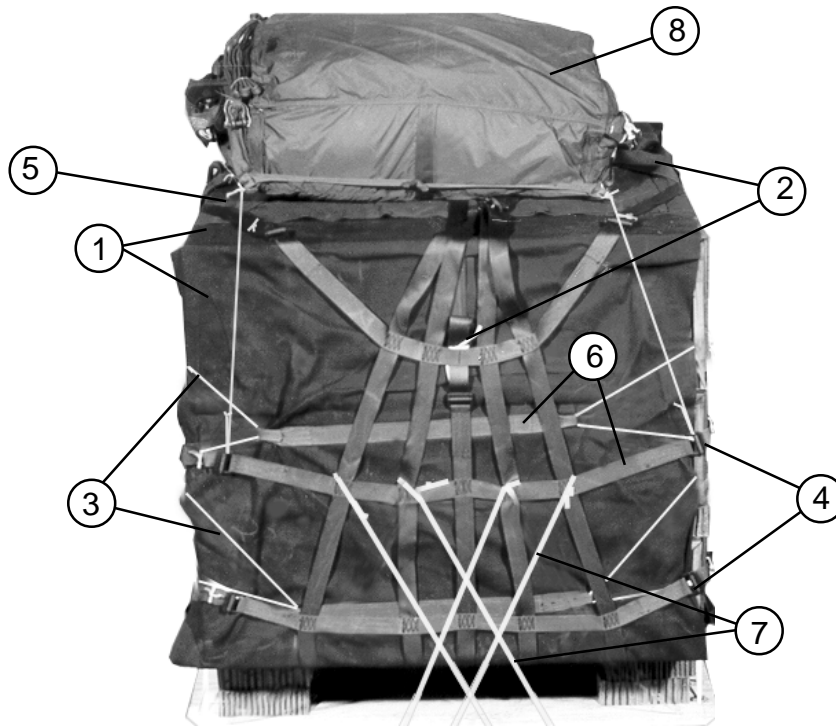

Figure 2-10. Twelve TOW Missiles Loaded on the A-22 Cargo Bag



- ① Bring the A-22 cover up over the load, and fold excess material under as necessary.
- ② Pass the A-22 tie-down straps up over the load. Fasten and tighten the straps.
- ③ Lace each corner of the cover through the lacing loops with type III nylon cord to form a figure eight.
- ④ Fasten the lateral straps together around the A-22 cover. Pass the upper lateral straps around the top of the corners.
- ⑤ Attach the suspension webs to the D-rings of the support webs with the open side of the snaps facing inward. Tape the snaps to the D-rings.
- ⑥ Adjust all straps to make the sling assembly fit snugly. Pull the suspension webs to their full height. Adjust the upper lateral straps to prevent binding the upper part of the support web. Fold all excess straps and tie the folds with type I, 1/4-inch cotton webbing.
- ⑦ Make the skidboard ties according to FM 10-500-3/TO 13C7-1-11.
- ⑧ Prepare, attach, and safety one G-12E cargo parachute (with a 68-inch pilot parachute), or three G-14 cargo parachutes to the load according to FM 10-500-3/TO 13C7-1-11.

Figure 2-11. A-22 Cargo Bag Secured

MARKING THE RIGGED LOAD

2-9. Mark the rigged load as described in Chapter 1, FM 10-500-3/TO 13C7-1-11. Complete the Shipper's Declaration for Dangerous Goods.



CAUTION
Make the rigger inspection described in Chapter 1, FM 10-500-3/TO 13C7-1-11 before the load leaves the rigging site.

RIGGED LOAD DATA

Weight.....1,394 pounds
 Width.....48 inches
 Height.....69 inches
 Length.....58 inches

Figure 2-12. Twelve TOW Missiles Rigged in an A-22 Cargo Bag for Low-Velocity Airdrop

EQUIPMENT REQUIRED

2-10. The equipment required to rig this load is listed in Table 2-2.

Table 2-2. Equipment Required to Rig Twelve TOW Missiles in an A-22 Cargo Bag for Low-velocity Airdrop

National Stock Number	Item	Quantity
8040-00-273-8713	Adhesive, paste, 1-gal	As required
1670-00-587-3421	Bag, cargo, aerial delivery, A-22	1
4020-00-240-2146	Cord, nylon, type III, 550-lb	As required
1670-00-753-3928	Pad, energy-dissipating, honeycomb	2 sheets
1670-01-065-3751	Parachute, cargo, 64-ft diam, G-12E <u>or</u>	1
1670-00-999-2658	Parachute, cargo, G-14	3
1670-00-216-7297	Parachute, pilot, 68-in diam	1
5530-00-914-5118	Plywood, 1-by 48- by 53 1/2-in	1
5530-00-128-4981	Plywood, 3/4- by 48- by 58-in (add two if honeycomb is not used)	
7510-00-266-5016	Tape, adhesive, 2-in	As required
8310-00-917-3945	Thread, cotton, ticket number 8/7 (ticket nr 5)	As required
1670-00-937-0271	Tie-down assembly, 15-ft	2
8305-00-268-2411	Webbing, type I, cotton, 1/4-in	As required
8305-00-082-5752	Webbing, nylon, tubular, 1/2-in	As required

SECTION III - RIGGING 12 MISSILE OVERPACKS IN AN A-22 CARGO BAG FOR HIGH-VELOCITY AIRDROP

DESCRIPTION OF LOAD

2-11. This load consists of 12 TOW missiles in overpacks. The 12 missiles are rigged in a standard A-22 cargo bag. The load requires one 26-foot, high-velocity cargo parachute.

RIGGING A-22 CARGO BAG

- 2-12. Rig the A-22 cargo bag as described below.
- a. Prepare the skid and honeycomb as shown in Figure 2-13.
 - b. Position and secure the missiles as shown in Figure 2-14.
 - c. Finish rigging the A-22 cargo bag as shown in Figure 2-15 and according to FM 10-500-3/TO 13C7-1-11.

ATTACHING CARGO PARACHUTE

2-13. Prepare and attach one 26-foot, high-velocity cargo parachute as shown in Figure 2-16, and according to FM 10-500-3/TO 13C7-1-11.

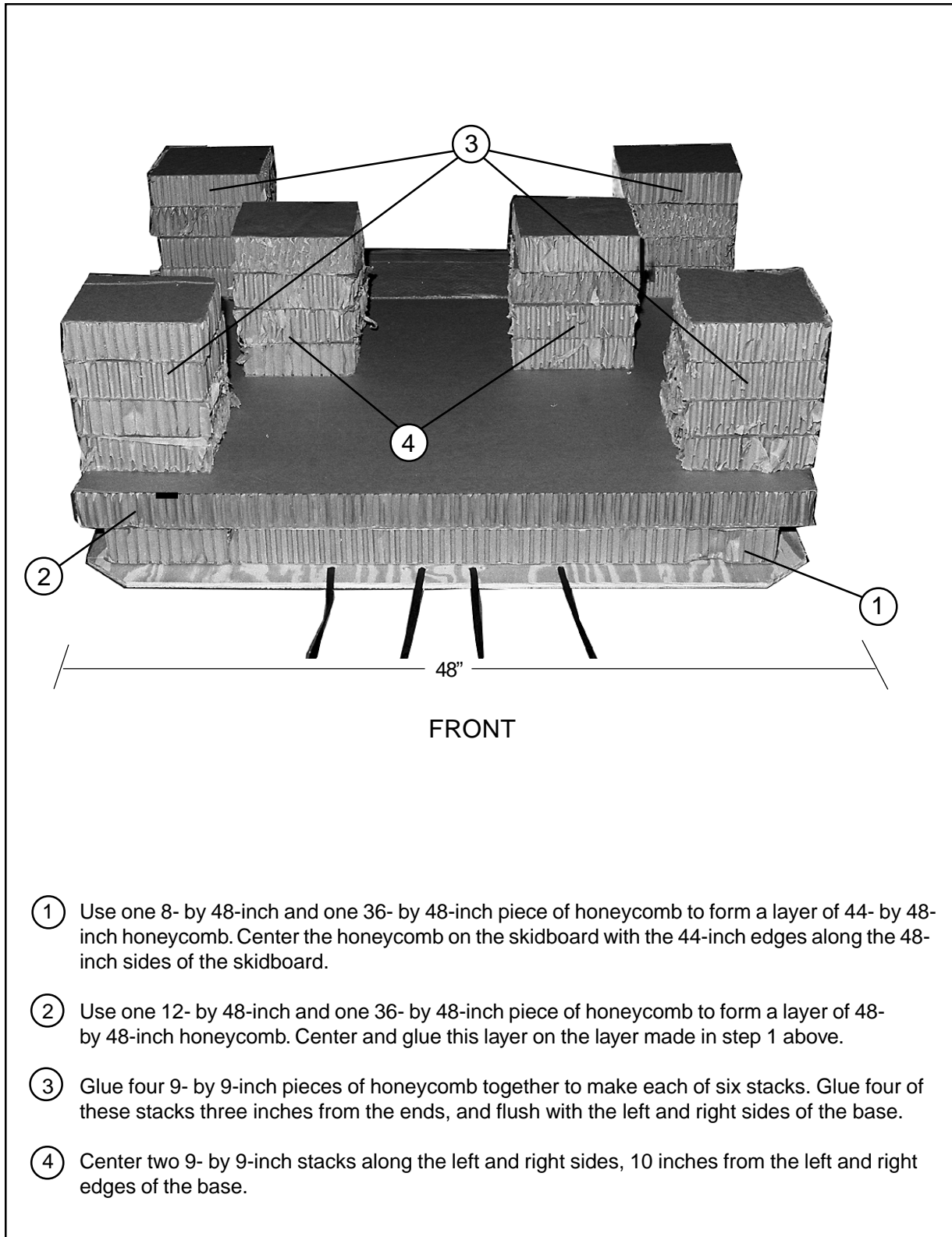

- ① Use one 8- by 48-inch and one 36- by 48-inch piece of honeycomb to form a layer of 44- by 48-inch honeycomb. Center the honeycomb on the skidboard with the 44-inch edges along the 48-inch sides of the skidboard.
- ② Use one 12- by 48-inch and one 36- by 48-inch piece of honeycomb to form a layer of 48- by 48-inch honeycomb. Center and glue this layer on the layer made in step 1 above.
- ③ Glue four 9- by 9-inch pieces of honeycomb together to make each of six stacks. Glue four of these stacks three inches from the ends, and flush with the left and right sides of the base.
- ④ Center two 9- by 9-inch stacks along the left and right sides, 10 inches from the left and right edges of the base.

Figure 2-13. Skid and Honeycomb Prepared

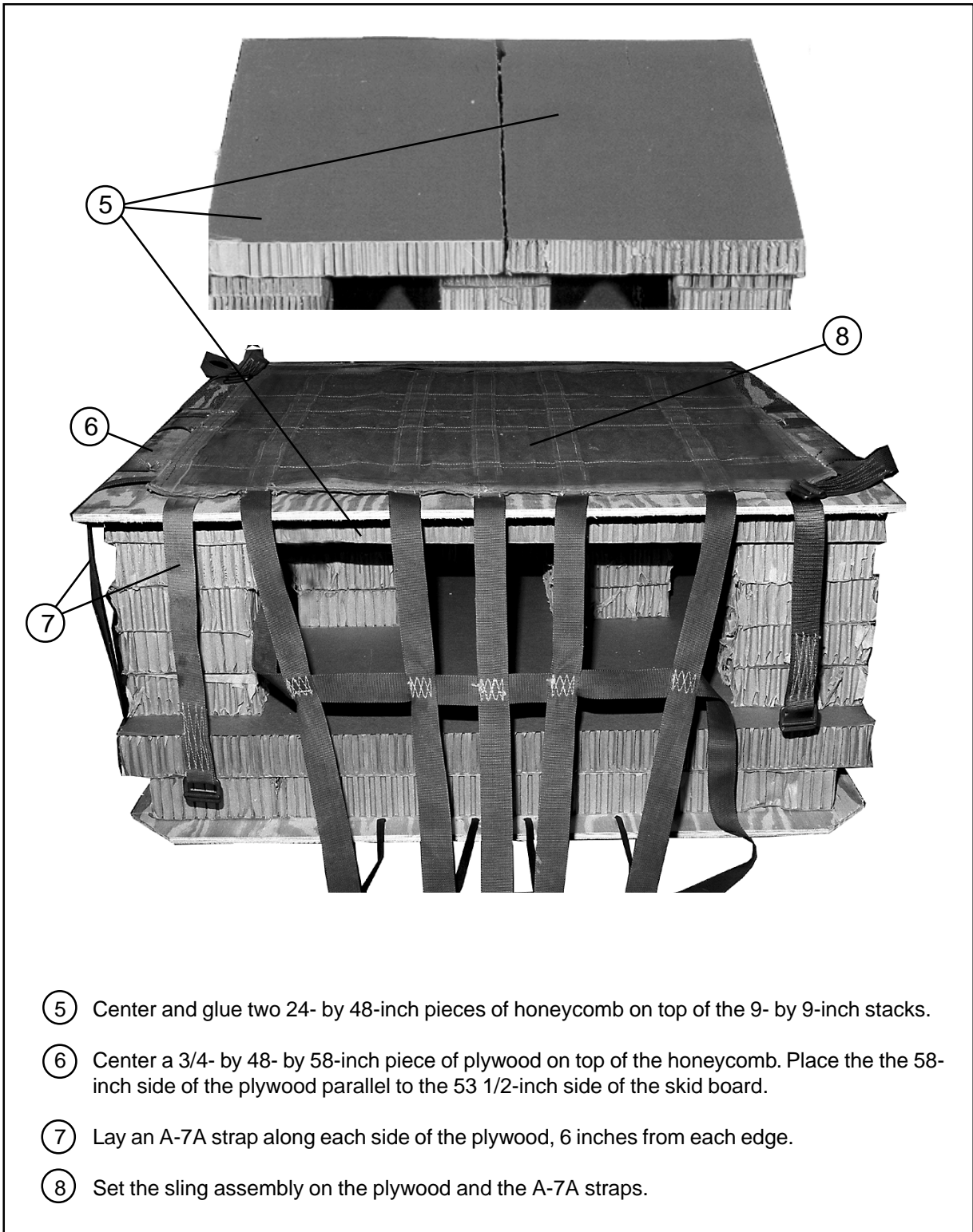

- ⑤ Center and glue two 24- by 48-inch pieces of honeycomb on top of the 9- by 9-inch stacks.
- ⑥ Center a 3/4- by 48- by 58-inch piece of plywood on top of the honeycomb. Place the the 58-inch side of the plywood parallel to the 53 1/2-inch side of the skid board.
- ⑦ Lay an A-7A strap along each side of the plywood, 6 inches from each edge.
- ⑧ Set the sling assembly on the plywood and the A-7A straps.

Figure 2-14. Skid and Honeycomb Prepared (Continued)

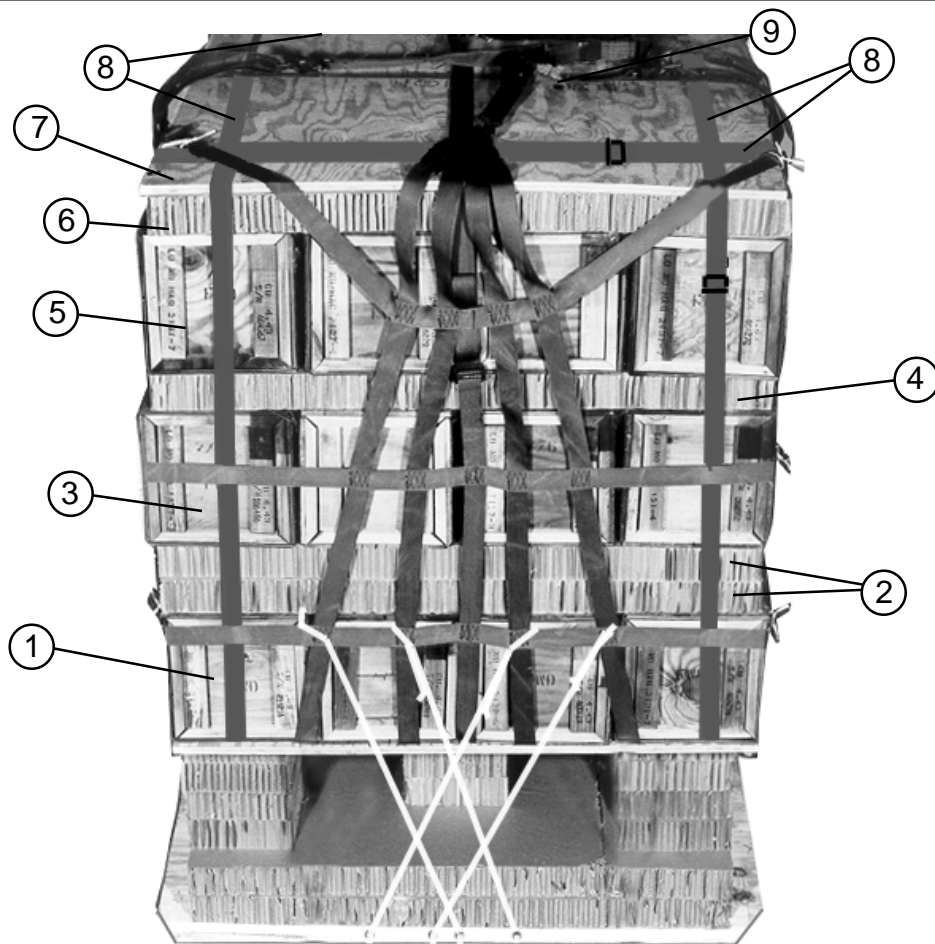

- ① Place four missiles on the scuff pad.
- ② Place two layers of honeycomb on the missiles. Use a 36- by 48-inch and a 22- by 48-inch piece of honeycomb to form each layer.
- ③ Place four missiles on the layers of honeycomb.
- ④ Place one 48- by 58-inch layer of honeycomb on the missiles.
- ⑤ Place four missiles on the layer of honeycomb.
- ⑥ Place one 48- by 58-inch layer of honeycomb over the missiles.
- ⑦ Place a 48- by 58-inch piece of plywood on top of the load.
- ⑧ Secure the four A-7A straps from under the scuff pad on top of the load.
- ⑨ Close the A-22 cargo bag according to FM 10-500-3/TO 13C7-1-11.

Figure 2-15. Missiles Positioned and Secured

MARKING THE RIGGED LOAD

2-14. Mark the rigged load as described in Chapter 1, FM 10-500-3/TO 13C7-1-11, using the data given in Figure 2-16. Complete the Shipper's Declaration for Dangerous Goods.

CAUTION
 Make the final inspection required by Chapter 1, FM 10-500-3/TO 13C7-1-11
 before the load leaves the rigging site.



RIGGED LOAD DATA

Weight.....	1,359 pounds
Width.....	48 inches
Height.....	83 inches
Length.....	58 inches

Figure 2-16. Twelve TOW Missiles Rigged in an A-22 Cargo Bag for High-Velocity Airdrop

EQUIPMENT REQUIRED

2-15. The equipment required to rig this load is listed in Table 2-3.

Table 2-3. Equipment required to Rig Twelve TOW Missiles in Overpacks in an A-22 Cargo Bag for High-Velocity Airdrop

National Stock Number	Item	Quantity
8040-00-273-8713	Adhesive, paste, 1-gal	As required
1670-00-587-3421	Bag, cargo, aerial delivery, A-22	1
1670-00-753-3928	Pad, energy-dissipating, honeycomb	5 sheets
1670-00-872-6109	Parachute, cargo, high-velocity, 26-ft	1
5530-00-914-5118	Plywood, 1-by 48- by 53 1/2-in	1
5530-00-128-4981	Plywood, 3/4-by 48- by 58-in	2
1670-00-251-1153	Strap, A-7A	4
7510-00-266-5016	Tape, adhesive, 2-in	As required
8310-00-917-3945	Thread, cotton, ticket number 8/7 (ticket nr 5)	As required
8305-00-268-2411	Webbing, type I, cotton, 1/4-in	As required
8305-00-082-5752	Webbing, nylon, tubular, 1/2-in	As required

Chapter 3

Rigging TOW Missiles in 1/4-ton Cargo Trailer for Low-velocity Airdrop

DESCRIPTION OF LOAD

3-1. The M416, 1/4-ton cargo trailer with eight boxed missiles is rigged on an 8-foot, type V airdrop platform for low-velocity airdrop. The load requires one G-11 cargo parachute. Each missile in its box weighs 87 pounds, and is 57 1/2 inches long, 12 inches high and 12 inches wide. The M416 with missiles weighs 1170 pounds. It is 109 inches long, 61 inches wide, and 44 inches high. The accompanying load consists of eight boxes of 105-millimeter ammunition. It weighs 588 pounds.

PREPARING PLATFORM

- 3-2. Prepare an 8-foot, type V airdrop platform as shown in Figure 3-1.
- a. Inspecting Platform. Inspect, or, assemble and inspect, the platform according to TM 10-1670-268-20&P/TO 13C7-52-22.
 - b. Installing Tandem Links. Install tandem links as shown in Figure 3-1.
 - c. Attaching and Numbering Clevises. Attach and number 24 clevis assemblies as shown in Figure 3-1.

NOTES:

- 1. The nose bumper may or may not be installed.**
- 2. Measurements given in this load are from the front edge of the platform, NOT from the front edge of the nose bumper.**

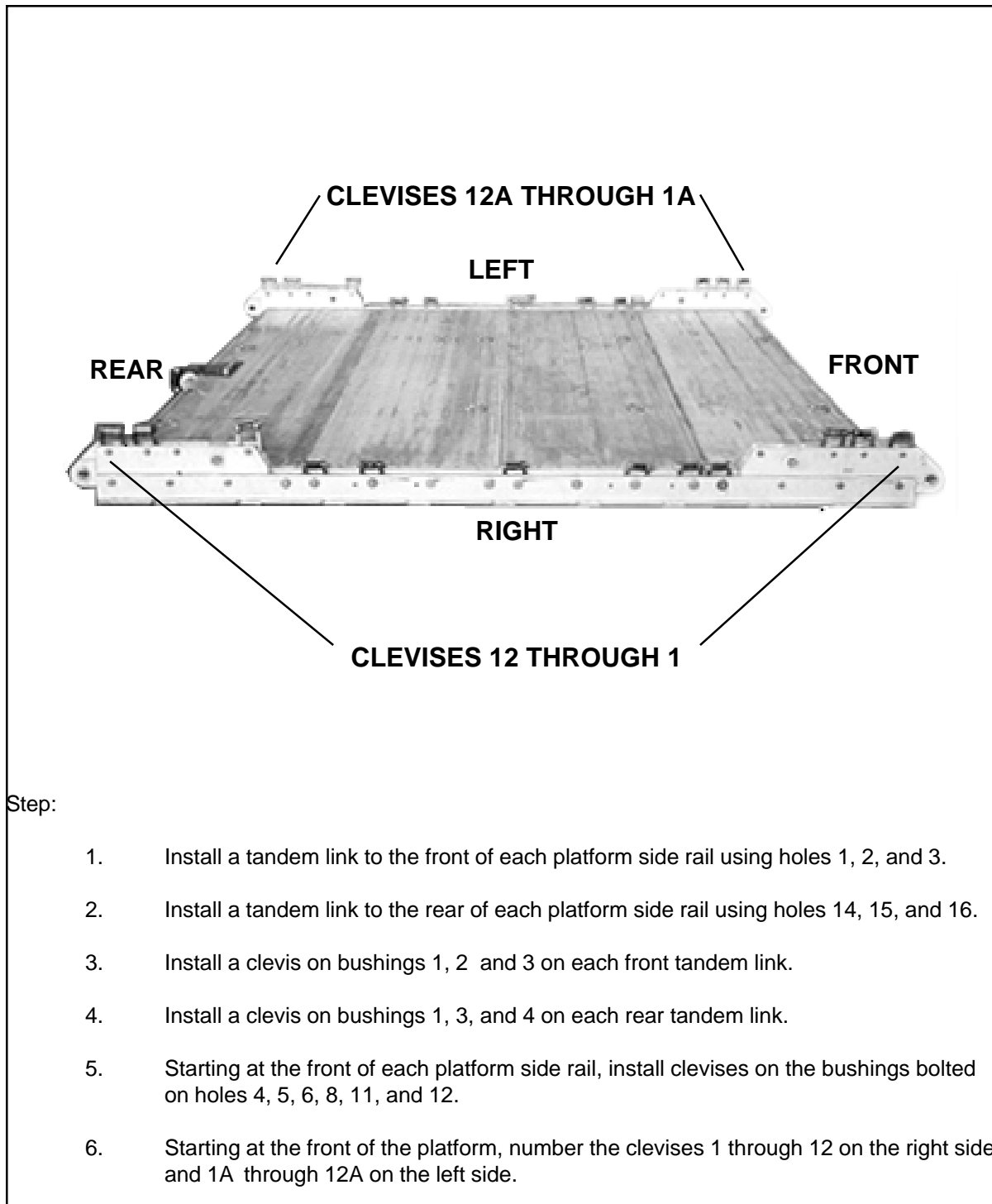

Figure 3-1. Platform Prepared

Stowing Accompanying Load

3-3. Place the honeycomb and stow the accompanying load as shown in Figure 3-2.

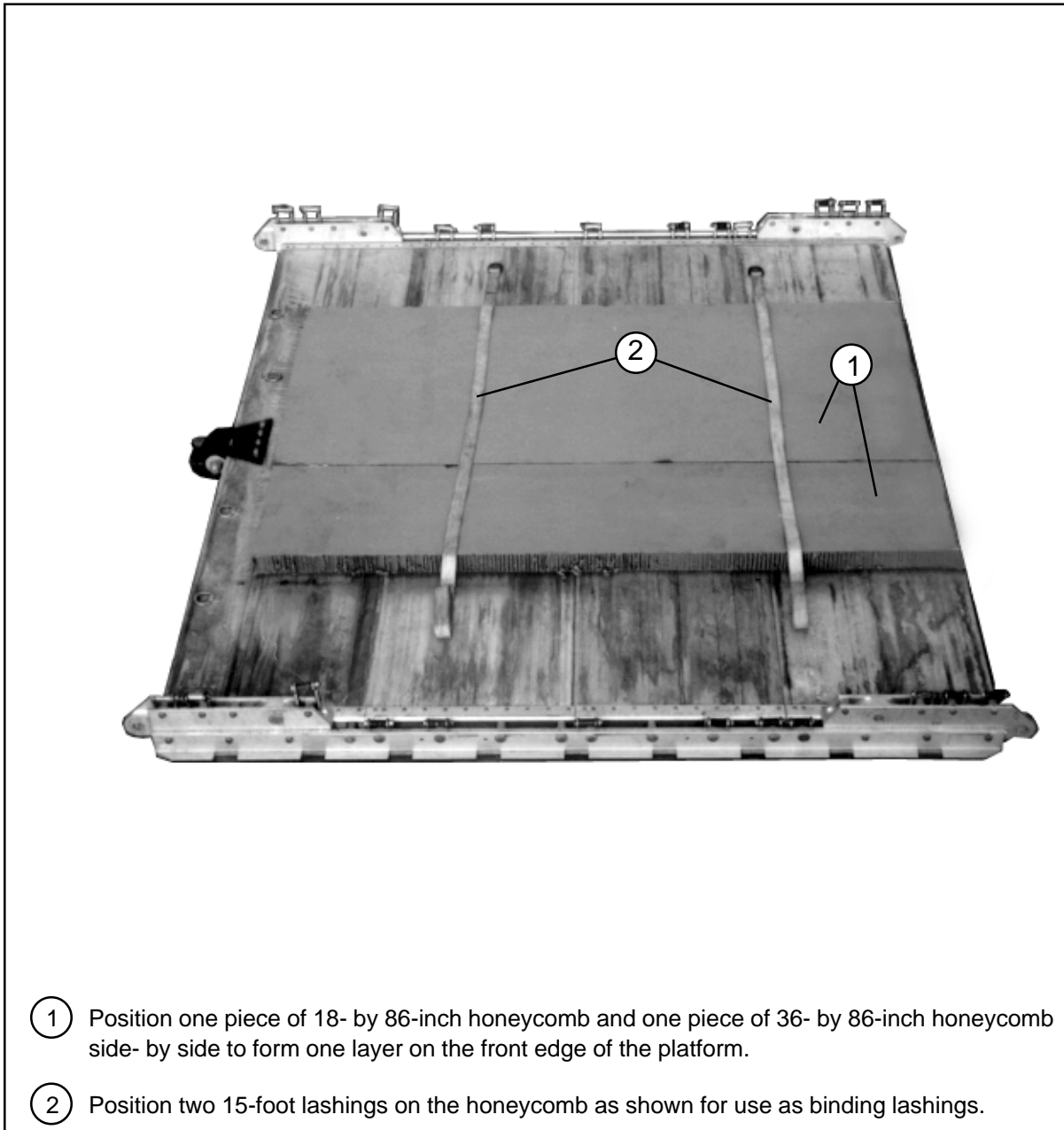
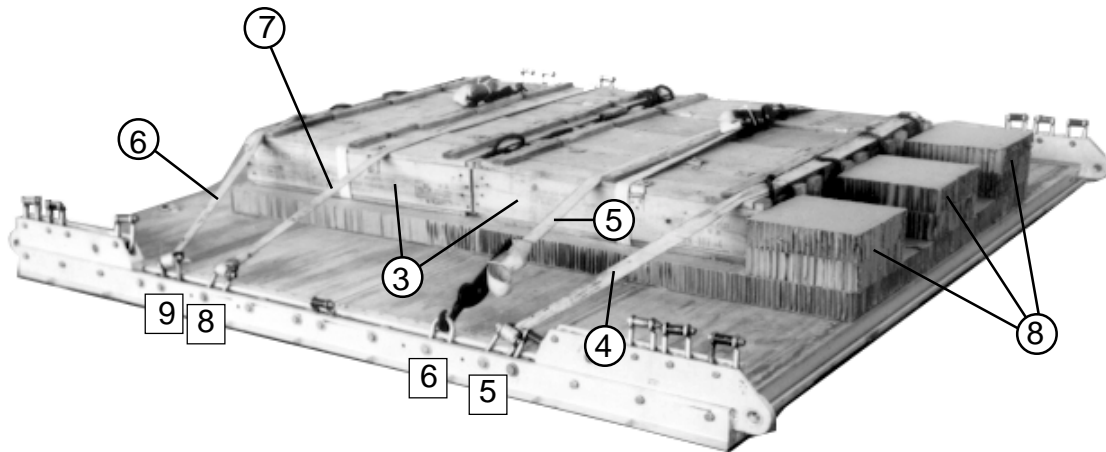

Figure 3-2. Accompanying Load Stowed

**Note: Other boxed ammunition may be used for this load.
Adapt the honeycomb and lashings for the ammunition rigged.**

Notice of Exception: Exception to FM 10-500-2/TO 13C7-1-5 is granted to rig ammunition on one layer of honeycomb.



- ③ Position eight boxes on the honeycomb as shown so that the four rearmost boxes are flush with the rear edge of the honeycomb. Secure the binding lashings placed in step 2 around the boxes.
- ④ Run a 15-foot lashing through clevis 5 and through its own D-ring. Bring the lashing through the front box carrying handles and fasten it to clevis 5A with a D-ring and a load binder.
- ⑤ Run a 15-foot lashing through clevis 6A and through its own D-ring. Bring the lashing over the top of the front boxes and fasten it to clevis 6 with a D-ring and a load binder.
- ⑥ Run a 15-foot lashing through clevis 9 and through its own D-ring. Bring the lashing through the rear box carrying handles and fasten it to clevis 9A with a D-ring and a load binder.
- ⑦ Run a 15-foot lashing through clevis 8 and through its own D-ring. Bring the lashing over the top of the rear boxes and fasten it to clevis 8A with a D-ring and a load binder.
- ⑧ Evenly space and glue three two-layer stacks of 12- by 12-inch honeycomb to the front edge of the base honeycomb.

Figure 3-2. Accompanying Load Stowed (continued)

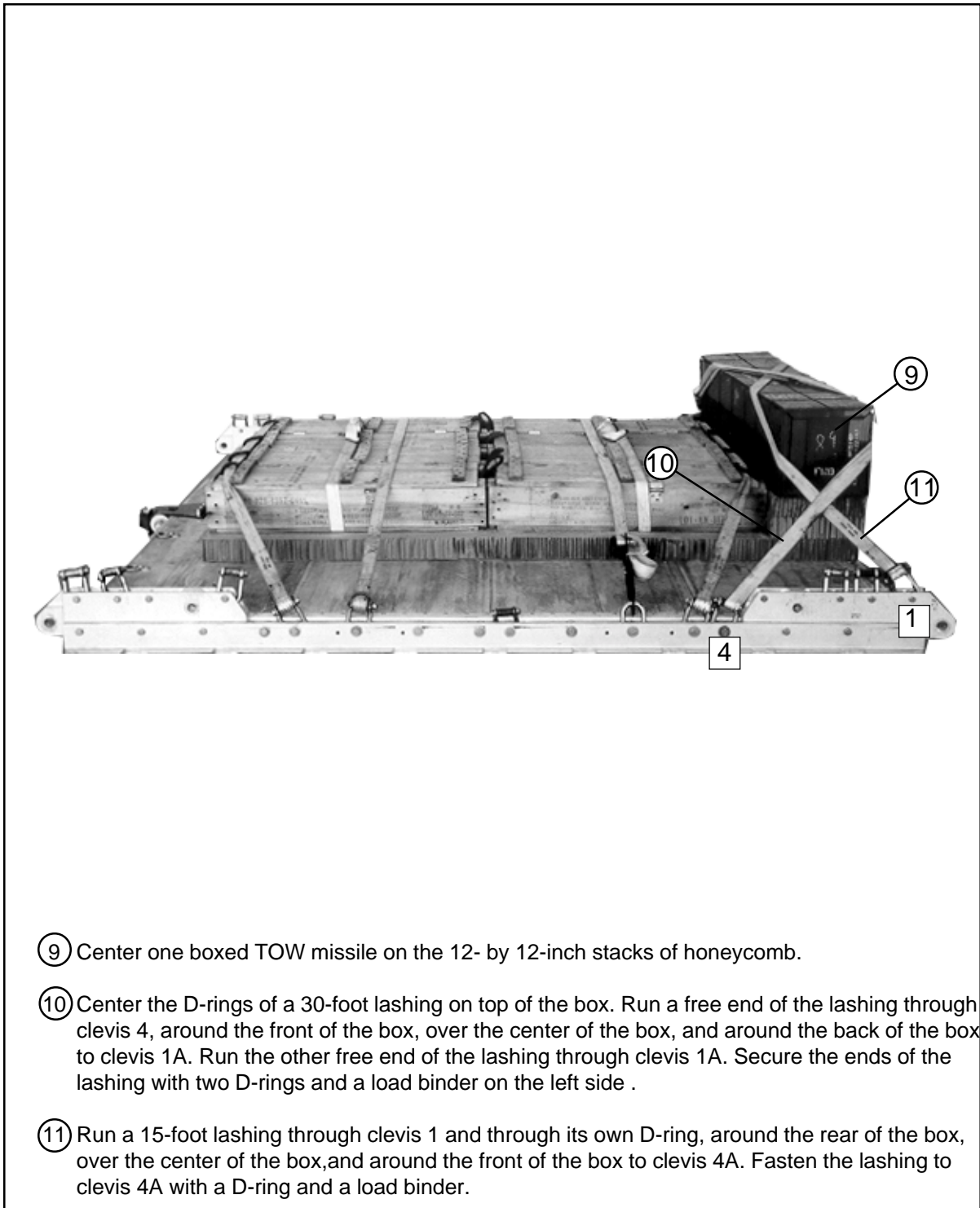

Figure 3-2. Accompanying Load Stowed (continued)

Preparing Missiles and Trailer

3-4. Prepare the missiles and trailer as shown in Figure 3-3.

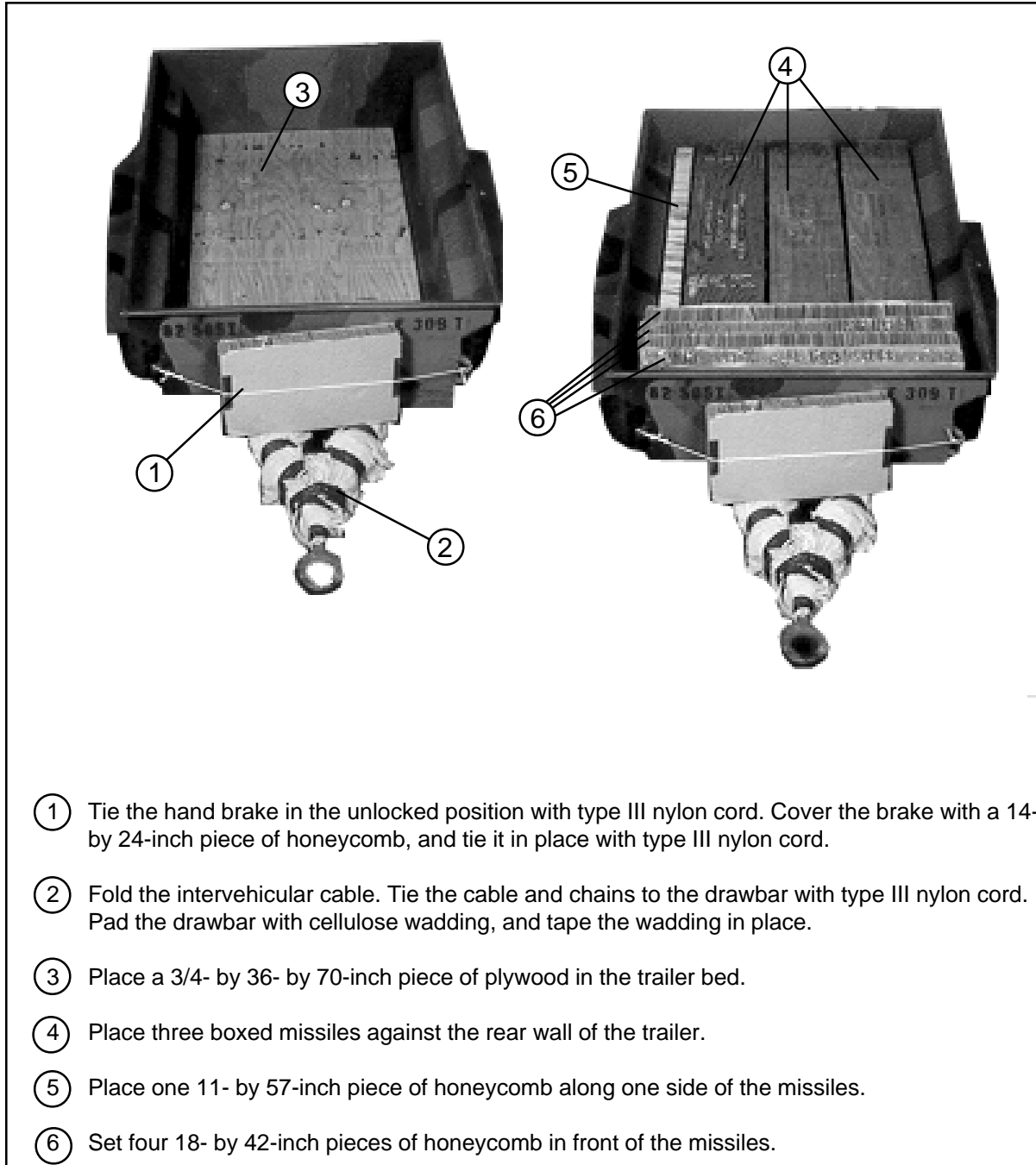
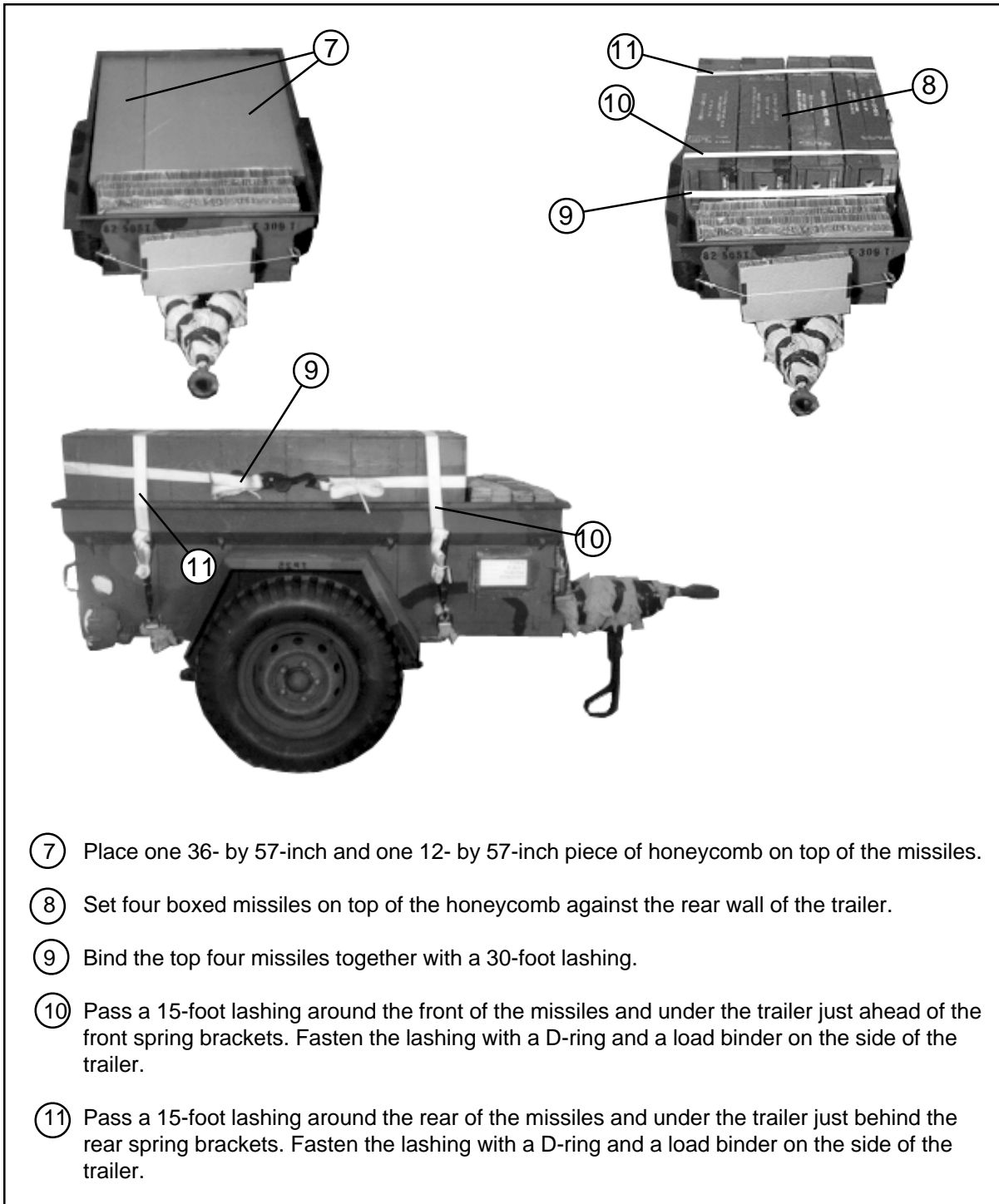

Figure 3-3. Missiles and Trailer Prepared



- ⑦ Place one 36- by 57-inch and one 12- by 57-inch piece of honeycomb on top of the missiles.
- ⑧ Set four boxed missiles on top of the honeycomb against the rear wall of the trailer.
- ⑨ Bind the top four missiles together with a 30-foot lashing.
- ⑩ Pass a 15-foot lashing around the front of the missiles and under the trailer just ahead of the front spring brackets. Fasten the lashing with a D-ring and a load binder on the side of the trailer.
- ⑪ Pass a 15-foot lashing around the rear of the missiles and under the trailer just behind the rear spring brackets. Fasten the lashing with a D-ring and a load binder on the side of the trailer.

Figure 3-3. Missiles and Trailer Prepared (continued)

Placing Honeycomb Stacks and Placing the Trailer

3-5. Place the honeycomb stacks on the accompanying load, and place the trailer on the stacks as shown in Figure 3-4.

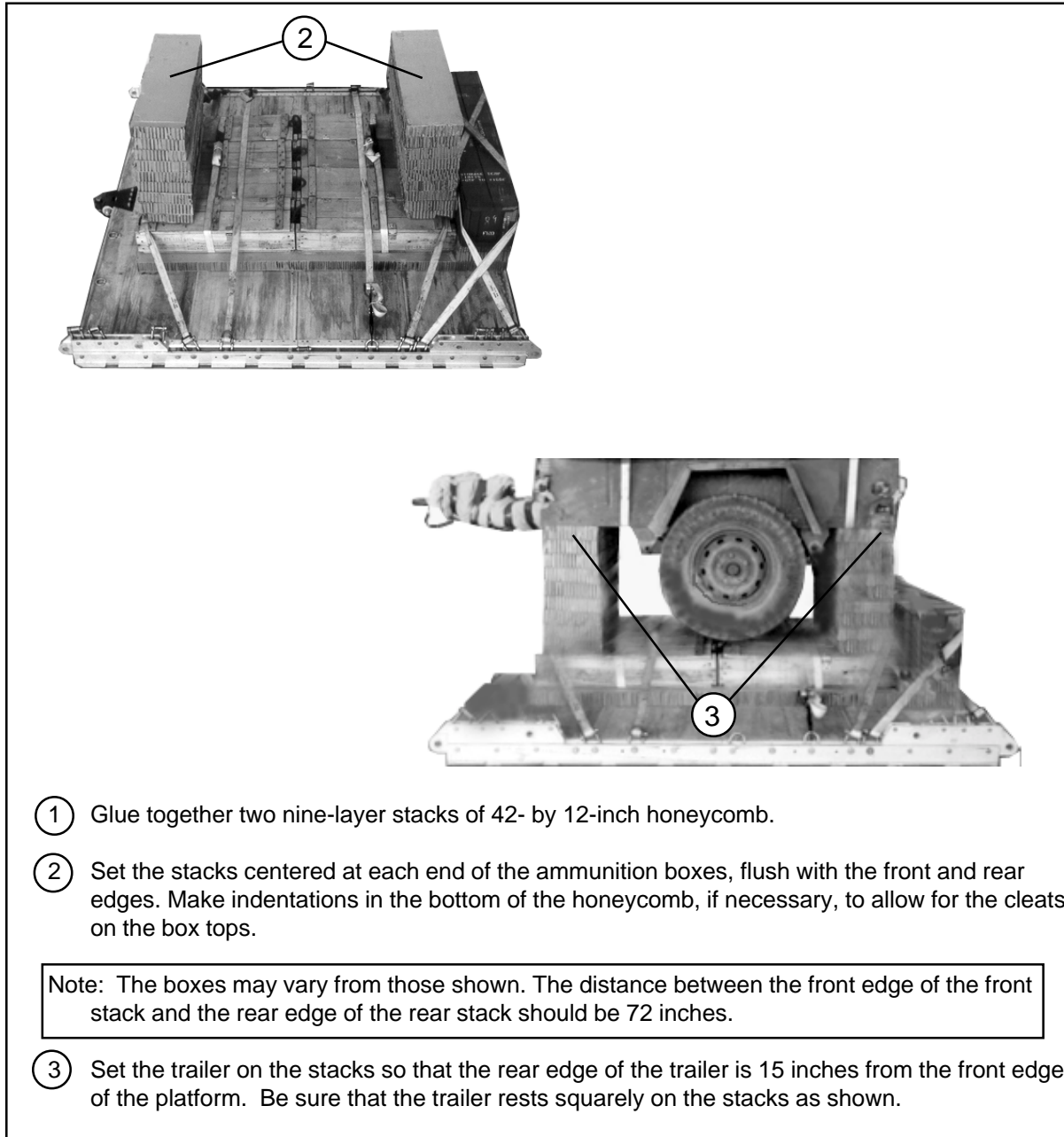
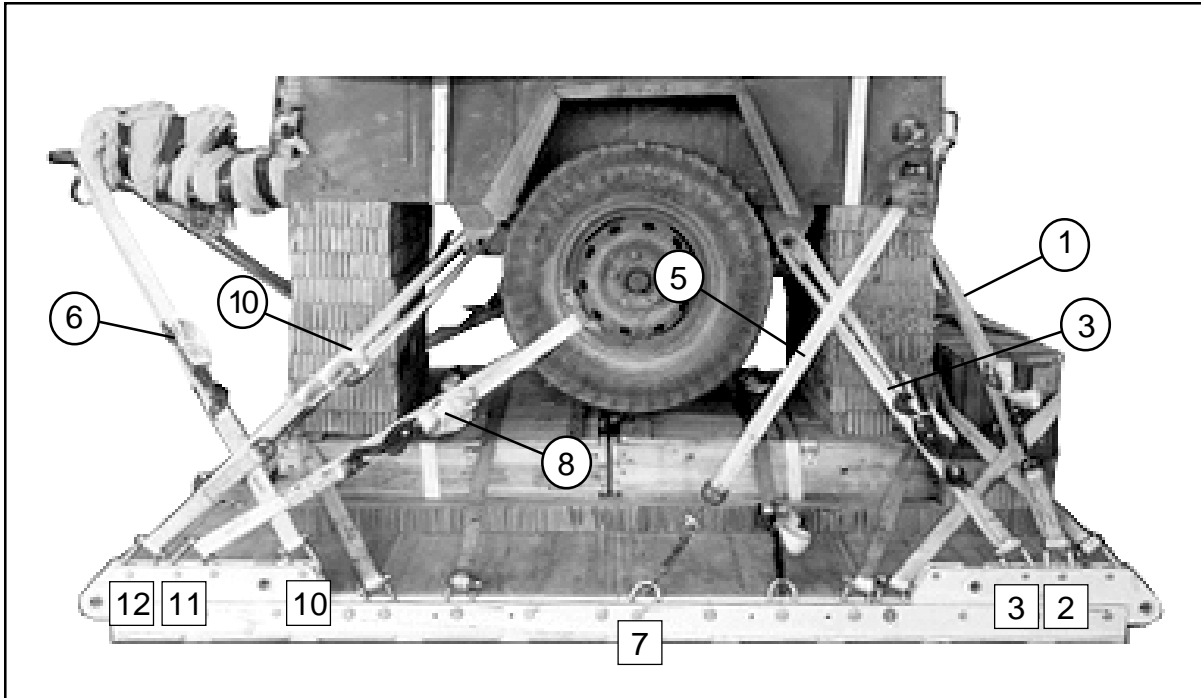

Figure 3-4. Honeycomb Stacks Placed and the Trailer Placed on the Stacks

Lashing Trailer

3-6. Lash the trailer to the platform as shown in Figure 3-5.



Lashing Number	Tie-down Clevis Number	Instructions
1	2	Pass lashing:
2	2A	Through right rear handle.
3	3	Through left rear handle.
4	3	Through rear spring bracket.
5	3A	Through rear spring bracket.
6	7 and 7A	Through clevis 7A, through both rear handles, to clevis 7.
7	10	Through lunette.
8	10A	Through lunette.
9	11	Through left wheel. (Pad the wheel opening.)
10	11A	Through right wheel. (Pad the wheel opening.)
11	12	Through front spring bracket.
12	12A	Through front spring bracket.

Figure 3-5. Lashings Installed

Installing Suspension Slings

3-7. Install four 12-foot, 2-loop, type XXVI nylon webbing slings according to FM 10-500-2/TO 13C7-1-5, and as shown in Figure 3-6.

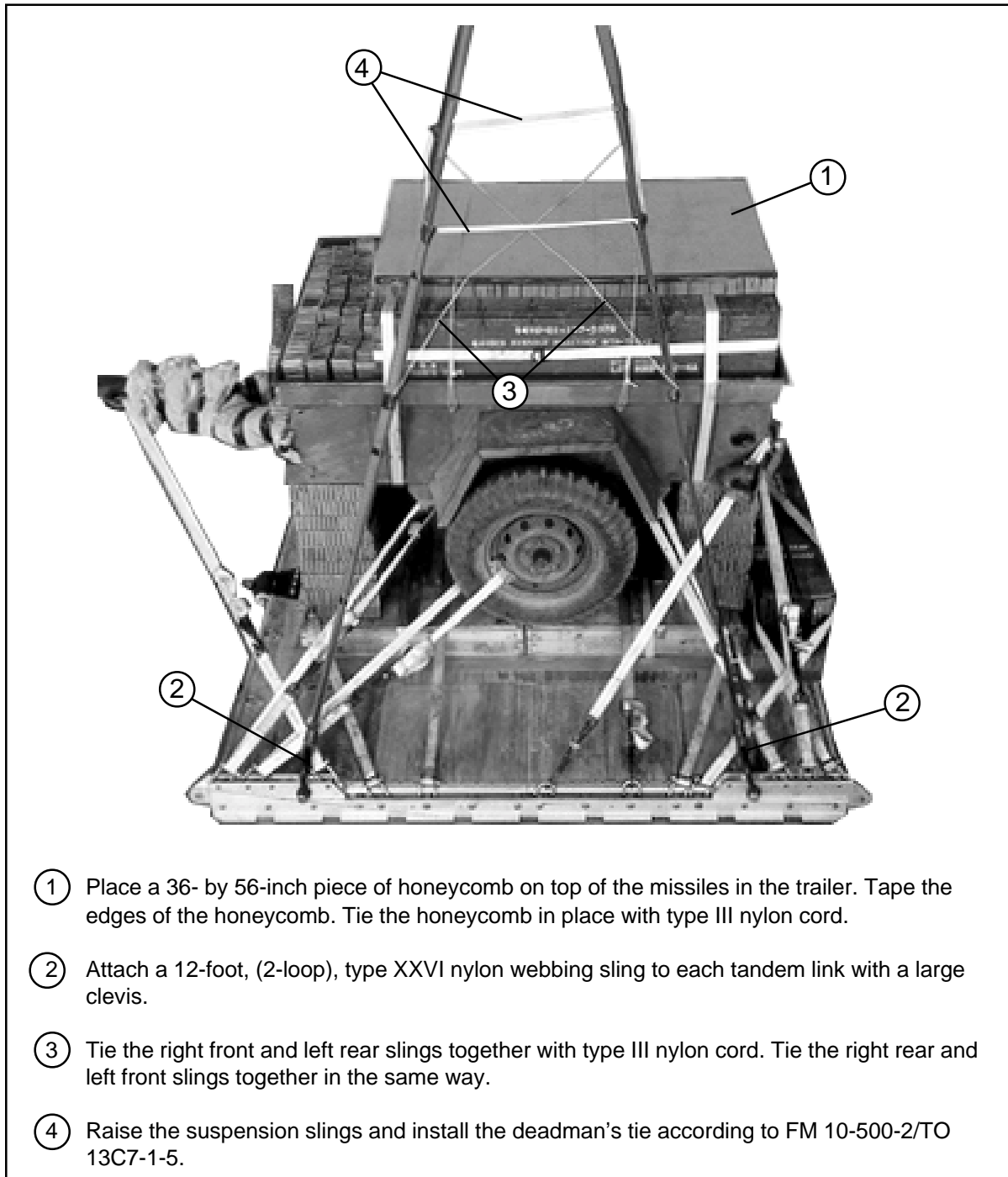
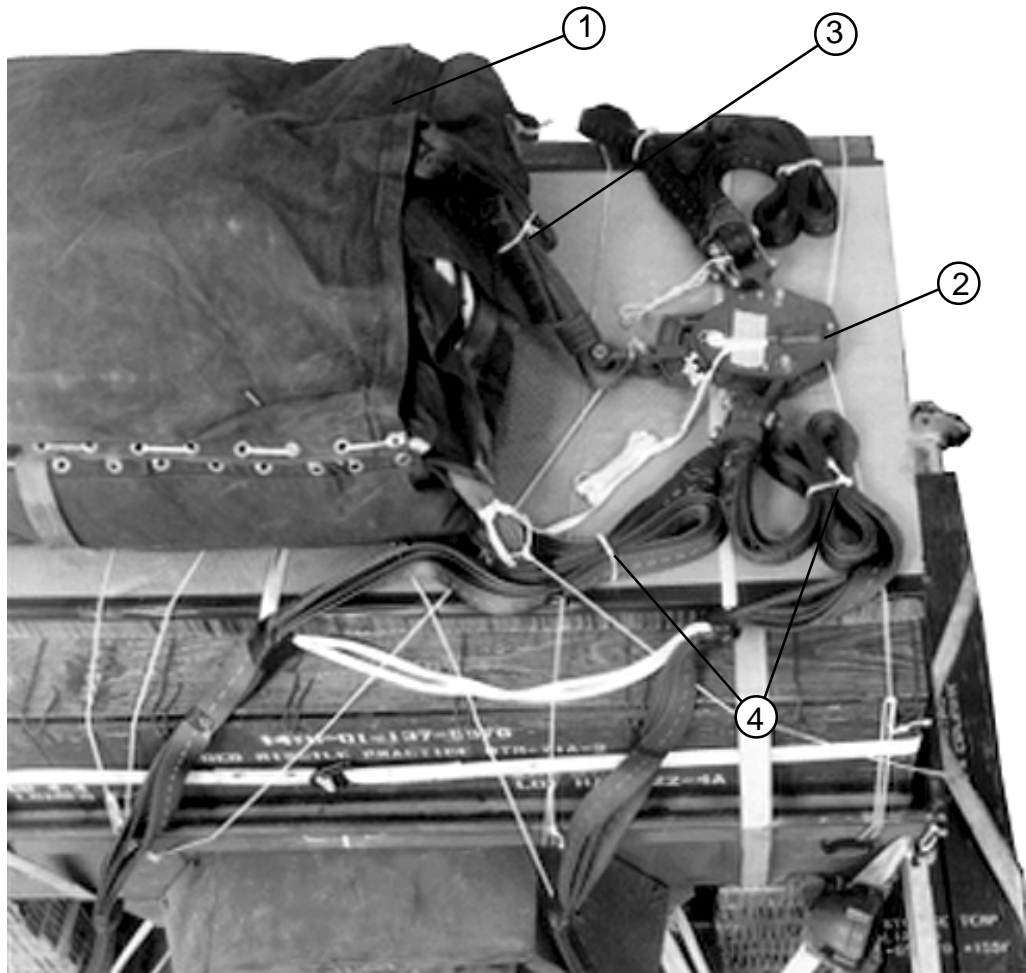

Figure 3-6. Suspension Slings Installed

Installing Cargo Parachute and Release Assembly

3-8. Install one G-11 cargo parachute and an M-1 cargo parachute release according to FM 10-500-2/TO 13C7-1-5, and as shown in Figure 3-7.



- ① Install one G-11 cargo parachute on the rear part of the honeycomb installed in Figure 3-6.
- ② Center an M-1 cargo parachute release in front of the parachute, and attach the parachute riser and suspension slings.
- ③ Fold any excess parachute riser, and tie the folds with type I, 1/4-inch cotton webbing.
- ④ Fold any excess suspension sling, and tie the folds with type I, 1/4-inch cotton webbing.

Figure 3-7. G-11 Cargo Parachute and M-1 Release Installed

Installing Extraction System

3-9. Install the EFTC extraction system according to FM 10-500-2/TO 13C7-1-5, and as shown in Figure 3-8.

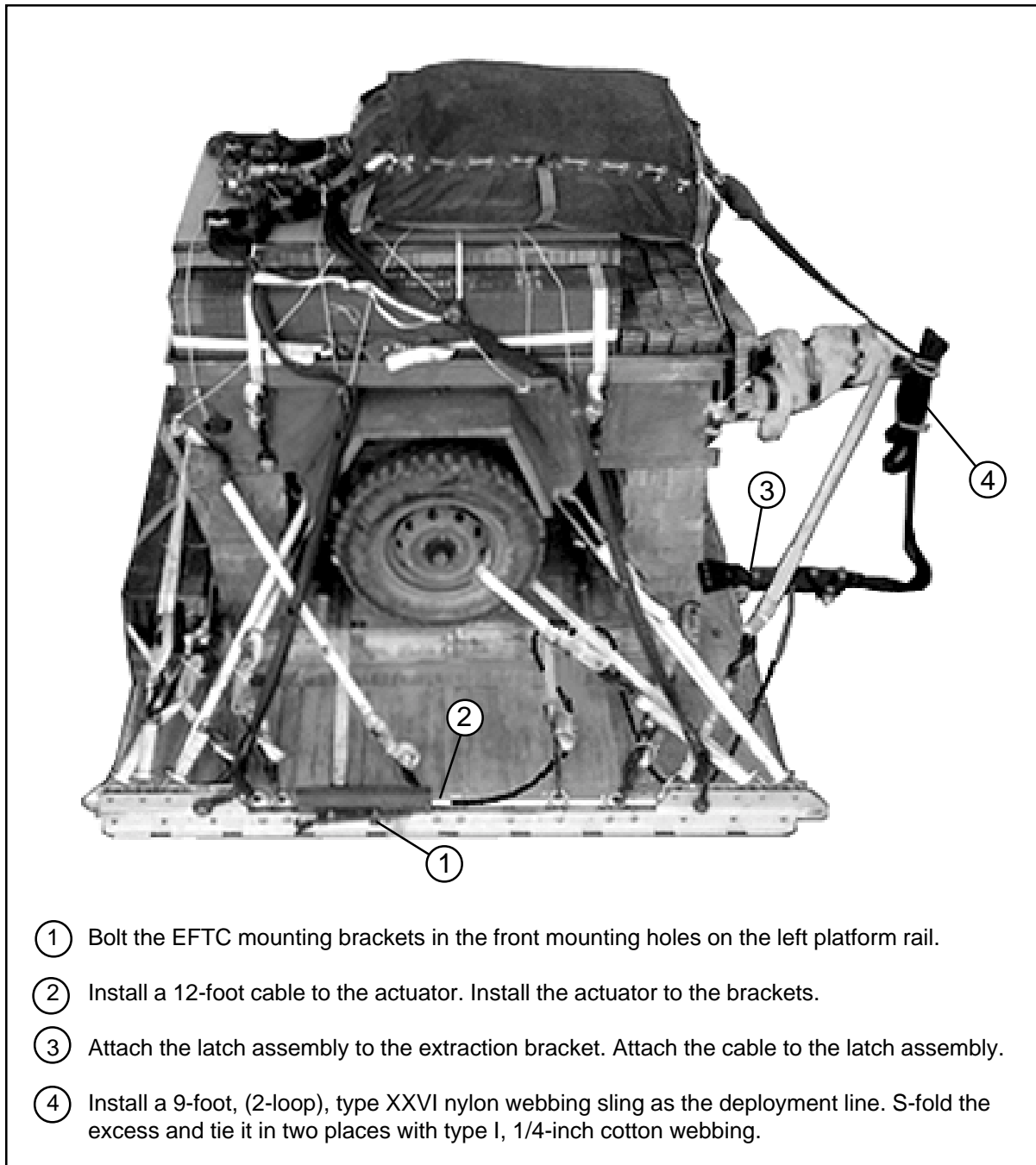

Figure 3-8. EFTC Installed

Installing Extraction Parachute

3-10. Select the extraction line and extraction parachute needed using the extraction line requirements table in FM 10-500-2/TO 13C7-1-5. Place the extraction parachute and extraction line on the load for installation in the aircraft.

Installing Provisions for Emergency Restraints

3-11. Select and install provisions for emergency restraints according to the emergency aft restraints requirements table in FM 10-500-2/TO 13C7-1-5.

Marking Rigged Load

3-12. Mark the rigged load according to FM 10-500-2/TO 13C7-1-5, and as shown in Figure 3-9. Complete the Shipper's Declaration for Dangerous Goods. If the load varies from the one shown, the weight, height, tip-off curve, CB, and parachute requirements must be recomputed.

Equipment Required

3-13. Use the equipment listed in Table 3-1 to rig this load.

CAUTION
 Make the final rigger inspection required by FM 10-500-2/
 13C7-1-5 before the load leaves the rigging site.

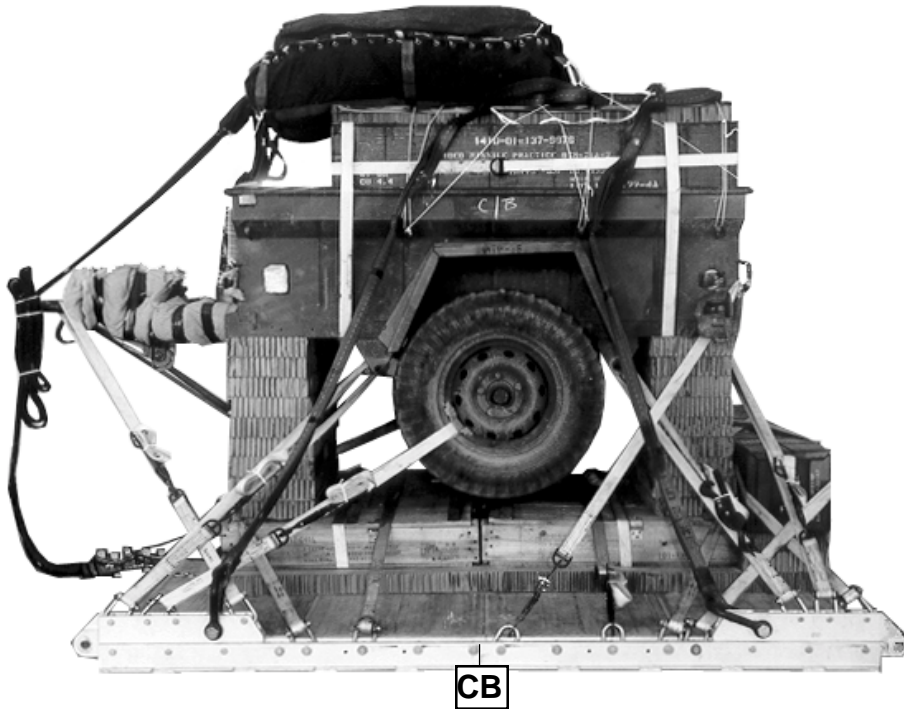

Rigged Load Data

Weight: Load shown	3,480 pounds
Maximum	5,250 pounds
Height	87 inches
Width	108 inches
Length	124 inches
Overhang: Front	0 inches
Rear	25 inches
CB (from front edge of platform)	51 inches
Extraction System (adds 18 inches to length of platform)	EFTC

Figure 3-9. M416 Trailer with Eight TOW Missiles Rigged for Low-Velocity Airdrop

Table 3-1. Equipment required for rigging the M416 trailer with eight TOW missiles for low-velocity airdrop

National Stock Number	Item	Quantity
8040-00-273-8713	Adhesive paste, 1-gal	As required
4030-00-090-5354	Clevis, suspension, 1-in (large)	5
4030-00-678-8562	Clevis, suspension, 3/4-in (medium)	2
4020-00-240-2146	Cord, nylon, type III, 550-lb	As required
1670-00-434-5783	Coupling, airdrop, extraction force transfer with cable, 12-ft	1
	Cover:	
1670-00-360-0328	Clevis, large	1
1670-00-360-0329	Link, type IV	1
8135-00-664-6958	Cushioning material, cellulose wadding	As required
1670-01-183-2678	Leaf, extraction line (line bag)	3
	Line, drogue (for C-17)	
1670-01-064-4452	60-ft (1-loop), type XXVI	1
	Line, extraction	
1670-01-064-4452	For C-130: 60-ft (1-loop), type XXVI	1
1670-01-107-7652	For C-141: 160-ft (1-loop), type XXVI	1
	For C-5:	
1670-01-107-7652	160-ft (1-loop), type XXVI	1
1670-01-107-7652	For C-17: 160-ft (1-loop), type XXVI	1
	Link assembly:	
1670-00-783-5988	Type IV (for C-17)	1
	Two-point, 3 3/4-in	1
5306-00-435-8994	Bolt, 1-in diam, 4 in long	(2)
5310-00-232-5165	Nut, 1-in, hexagonal	(2)
1670-00-003-1953	Plate, side, 3 3/4-in	(2)
5365-00-007-3414	Spacer, large	(2)

Table 3-1. Equipment required for rigging the M416 trailer with eight TOW missiles for low-velocity airdrop (continued)

National Stock Number	Item	Quantity
1670-00-753-3928	Pad, energy-dissipating, honeycomb, 3- by 36- by 96-in	8 sheets
	Parachute:	
1670-01-016-7841	Cargo, G-11B	1
1670-01-063-3715	Cargo extraction, 15-ft	1
1670-01-063-3715	Drogue, 15-ft (for C-17)	1
	Platform, airdrop, type V, 8-foot	
1670-01-353-8425	Bracket assembly, coupling	(1)
1670-01-162-2372	Clevis assembly, type V	(24)
1670-01-353-8424	Extraction bracket assembly	(1)
1670-01-162-2381	Link, tandem, suspension link assembly	(4)
5530-00-128-4981	Plywood, 3/4- by 48- by 96-in	1 sheet
1670-01-097-8816	Release, cargo parachute, M-1	1
	Sling, cargo airdrop	
	For suspension:	
1670-01-062-6303	12-ft (2-loop), type XXVI nylon webbing	4
	For deployment:	
1670-01-062-6304	9-ft (2-loop), type XXVI nylon webbing	1
1670-00-998-0116	Strap, parachute release, single	1
7510-00-266-5016	Tape, adhesive, 2-in	As required
1670-00-937-0271	Tie-down assembly, 15-ft	29
	Webbing:	
8305-00-268-2411	Cotton, 1/4-in, type	As required
8305-00-082-5752	Nylon, tubular, 1/2-in	As required
8305-00-261-8585	Type VIII	As required

Chapter 4

Rigging TOW Missiles in Boxes on Type V Platform for Low-velocity Airdrop

SECTION I- RIGGING MISSILES IN A-22 CARGO BAGS ON A TYPE V PLATFORM FOR LOW-VELOCITY AIRDROP

DESCRIPTION OF LOAD

4-1. Forty-eight boxed missiles are rigged twelve each in four A-22 cargo bags on a 12-foot, type V airdrop platform. Each boxed missile weighs 87 pounds and is 57 1/2 inches long, 12 inches high, and 12 inches wide. This load requires two G-11 cargo parachutes.

PREPARING PLATFORM

- 4-2. Prepare a 12-foot, type V airdrop platform as described below.
- a. Inspecting Platform. Inspect, or, assemble and inspect, the platform according to TM 10-1670-268-20&P/TO 13C7-52-22.
 - b. Installing Tandem Links. Install tandem links as shown in Figure 4-1.
 - c. Attaching and Numbering Clevises. Attach and number 20 clevis assemblies as shown in Figure 4-1.

NOTES:

- 1. The nose bumper may or may not be installed.**
- 2. Measurements given in this load are from the front edge of the platform, NOT from the front edge of the nose bumper.**

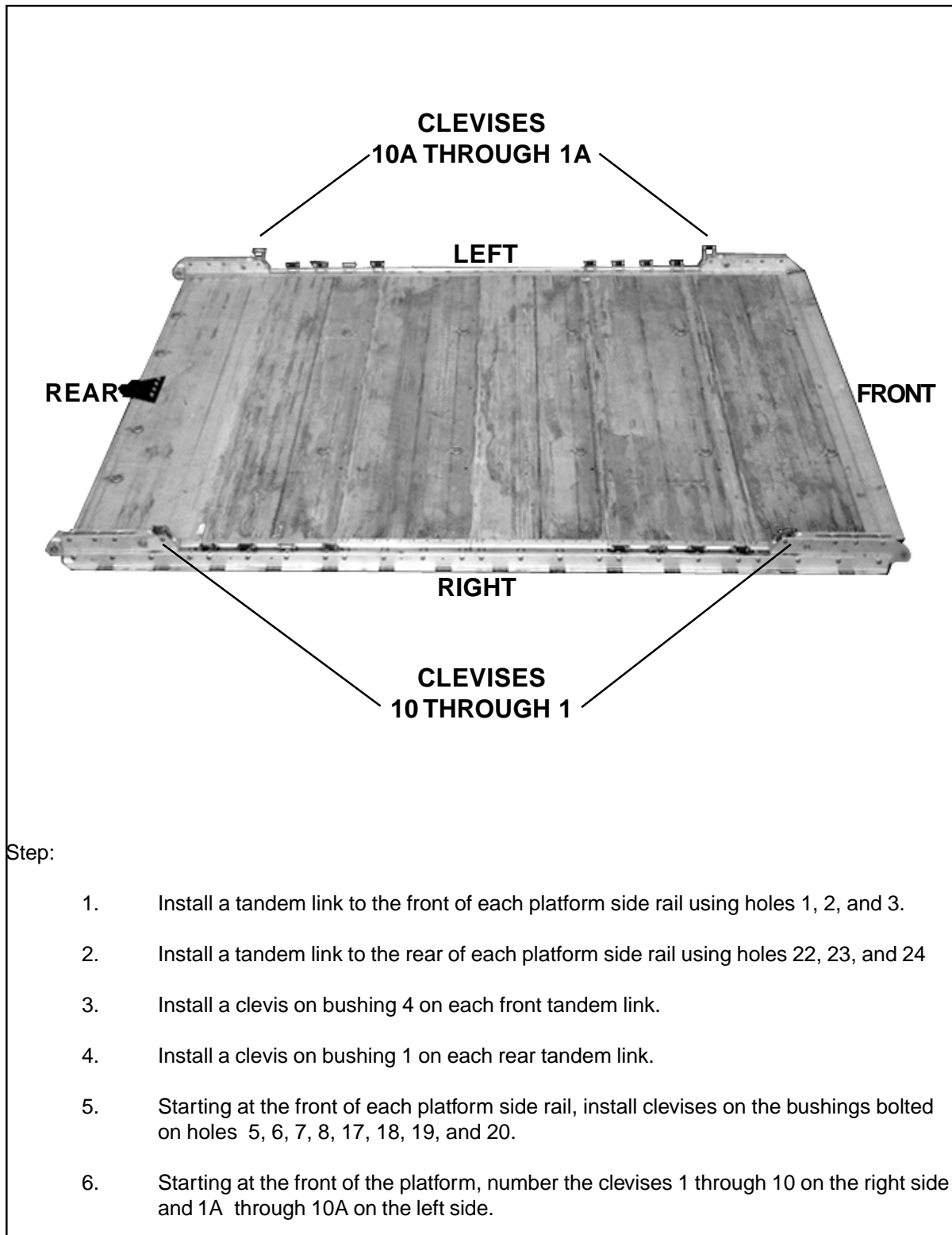

Figure 4-1. Platform Prepared

BUILDING AND PLACING HONEYCOMB STACKS

4-3. Build the honeycomb stacks and place them on the platform as shown in Figure 4-2.

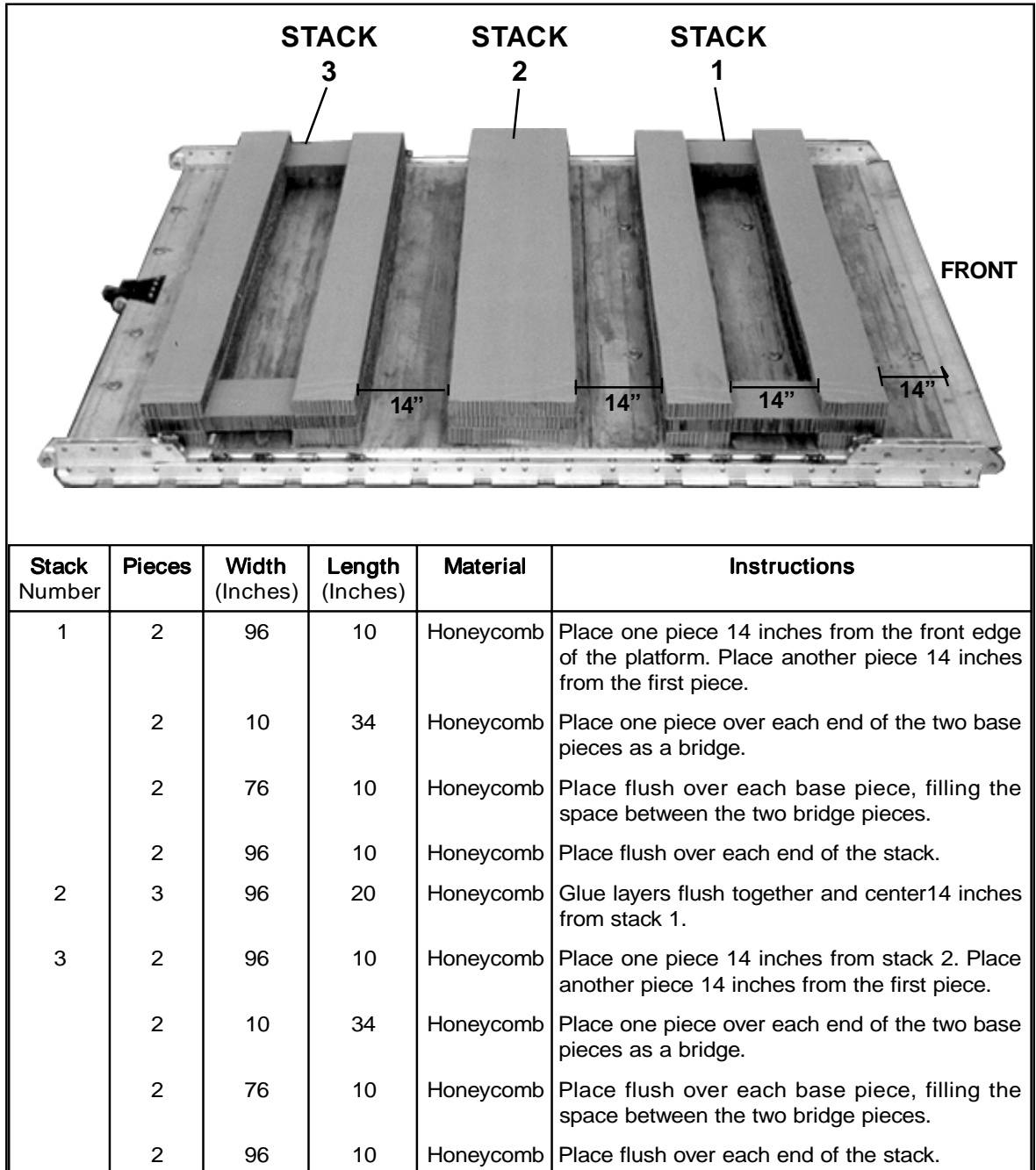

Figure 4-2. Honeycomb Stacks Prepared and Positioned

PLACING MISSILES IN A-22 CARGO BAGS

4-4. Place the missiles in four A-22 cargo bags as shown in Figure 4-3. Close the A-22 cargo bag according to FM 10-500-3/TO 13C7-1-11, and as shown in Figure 4-4.

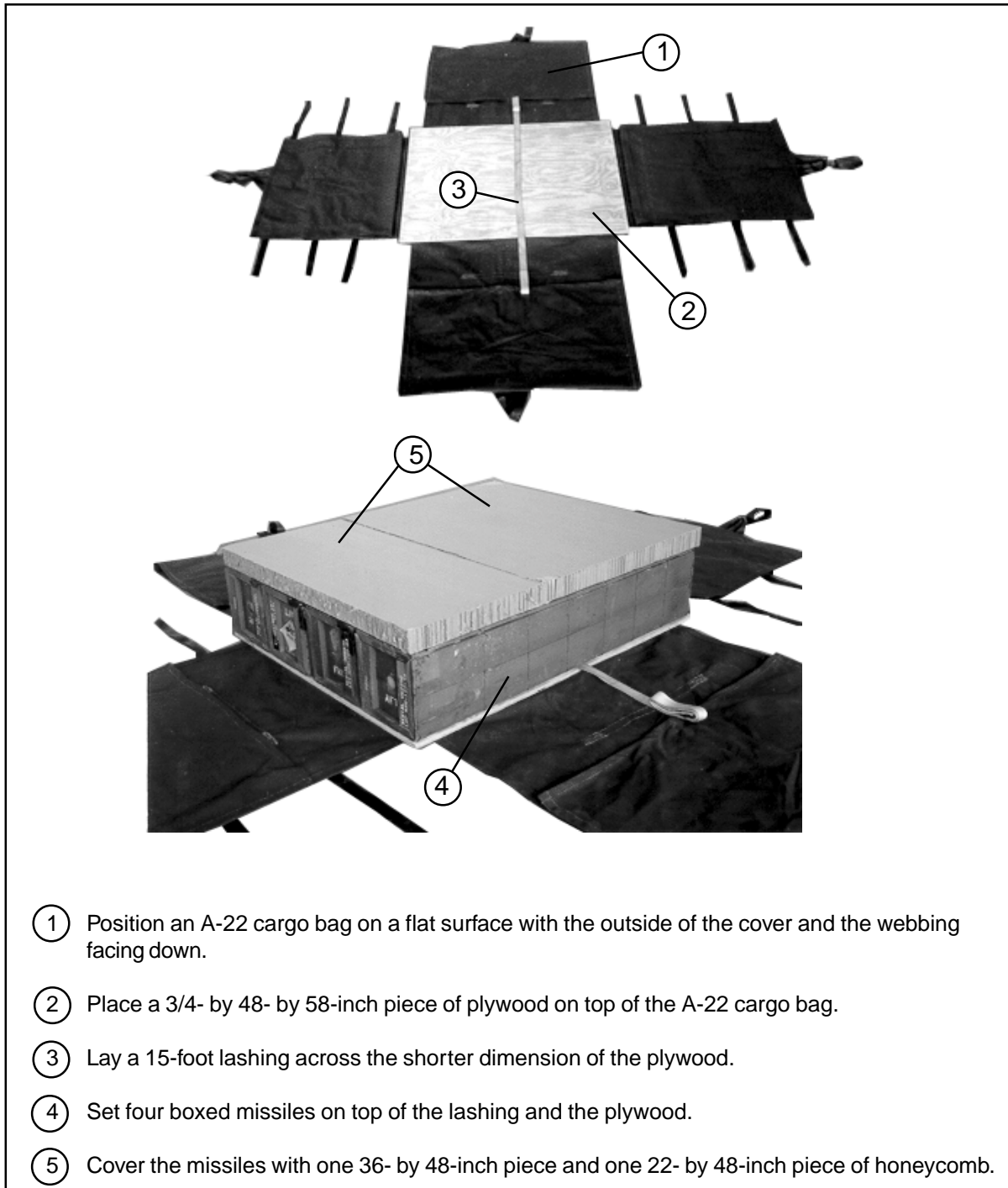
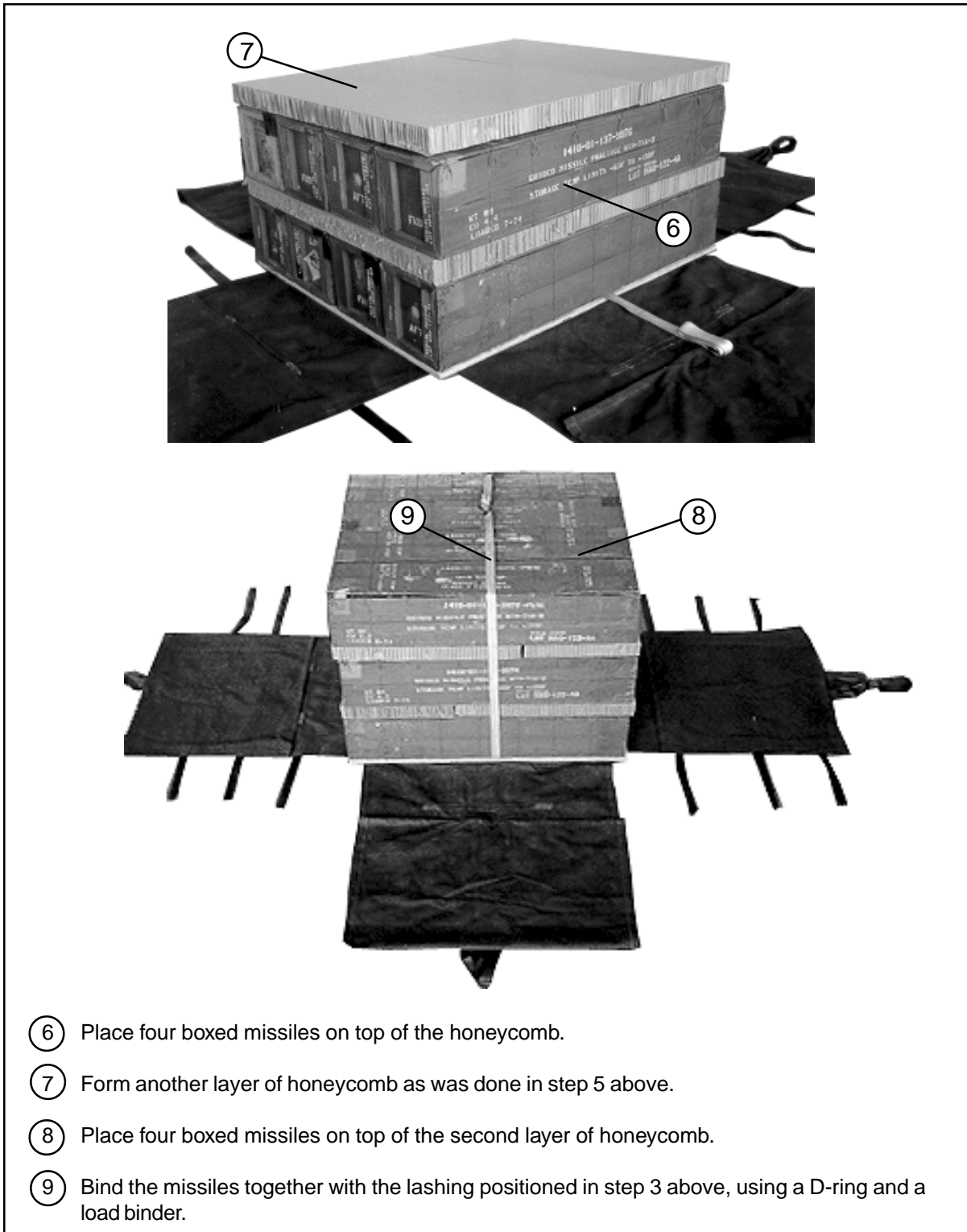
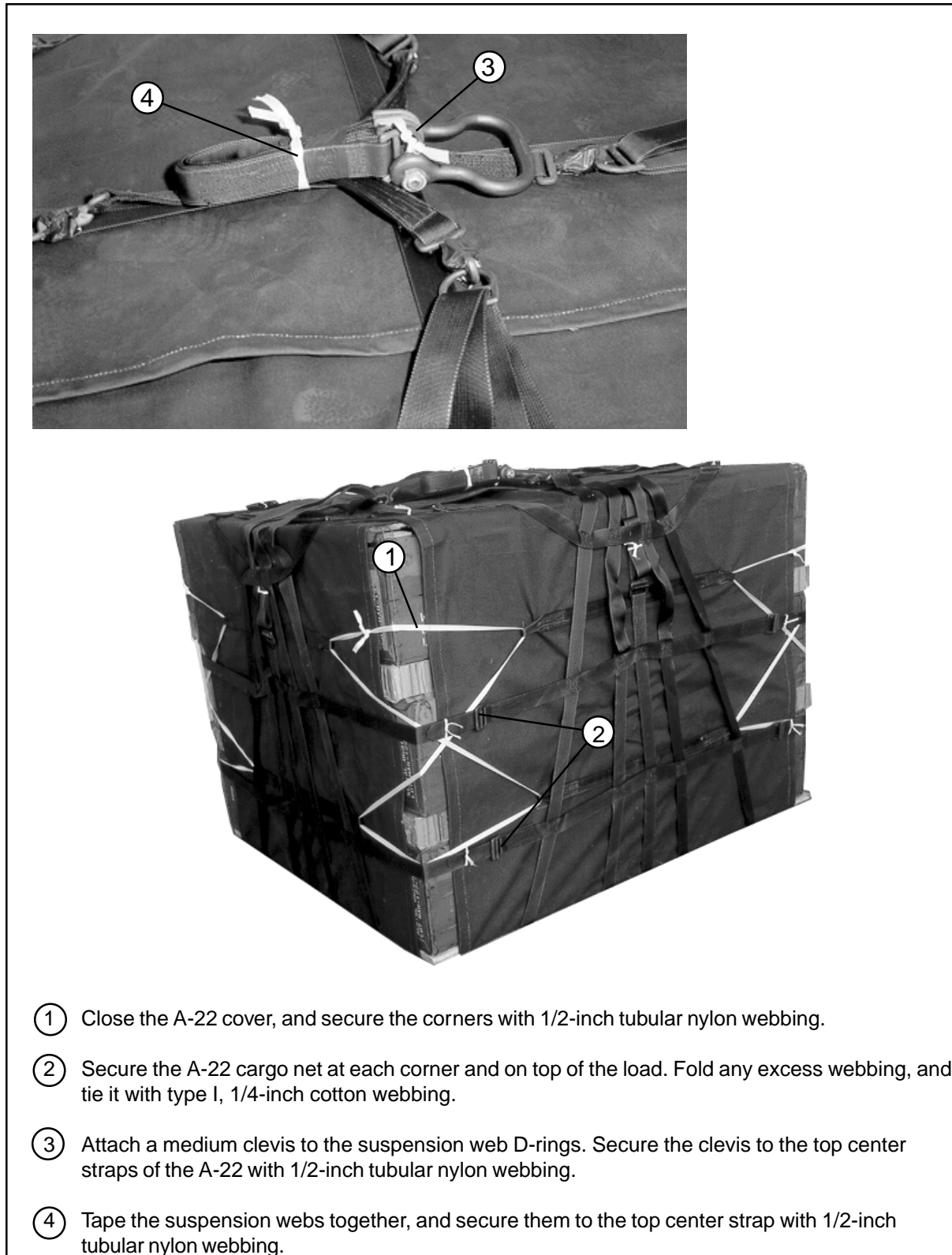

Figure 4-3. Missiles Placed in A-22 Cargo Bag



- ⑥ Place four boxed missiles on top of the honeycomb.
- ⑦ Form another layer of honeycomb as was done in step 5 above.
- ⑧ Place four boxed missiles on top of the second layer of honeycomb.
- ⑨ Bind the missiles together with the lashing positioned in step 3 above, using a D-ring and a load binder.

Figure 4-3. Missiles Placed in A-22 Cargo Bag (continued)



- ① Close the A-22 cover, and secure the corners with 1/2-inch tubular nylon webbing.
- ② Secure the A-22 cargo net at each corner and on top of the load. Fold any excess webbing, and tie it with type I, 1/4-inch cotton webbing.
- ③ Attach a medium clevis to the suspension web D-rings. Secure the clevis to the top center straps of the A-22 with 1/2-inch tubular nylon webbing.
- ④ Tape the suspension webs together, and secure them to the top center strap with 1/2-inch tubular nylon webbing.

Figure 4-4. A-22 cargo bag closed

PLACING MISSILES IN A-22 CARGO BAGS ON PLATFORM

4-5. Place the A-22 cargo bags on the honeycomb stacks as shown in Figure 4-5.

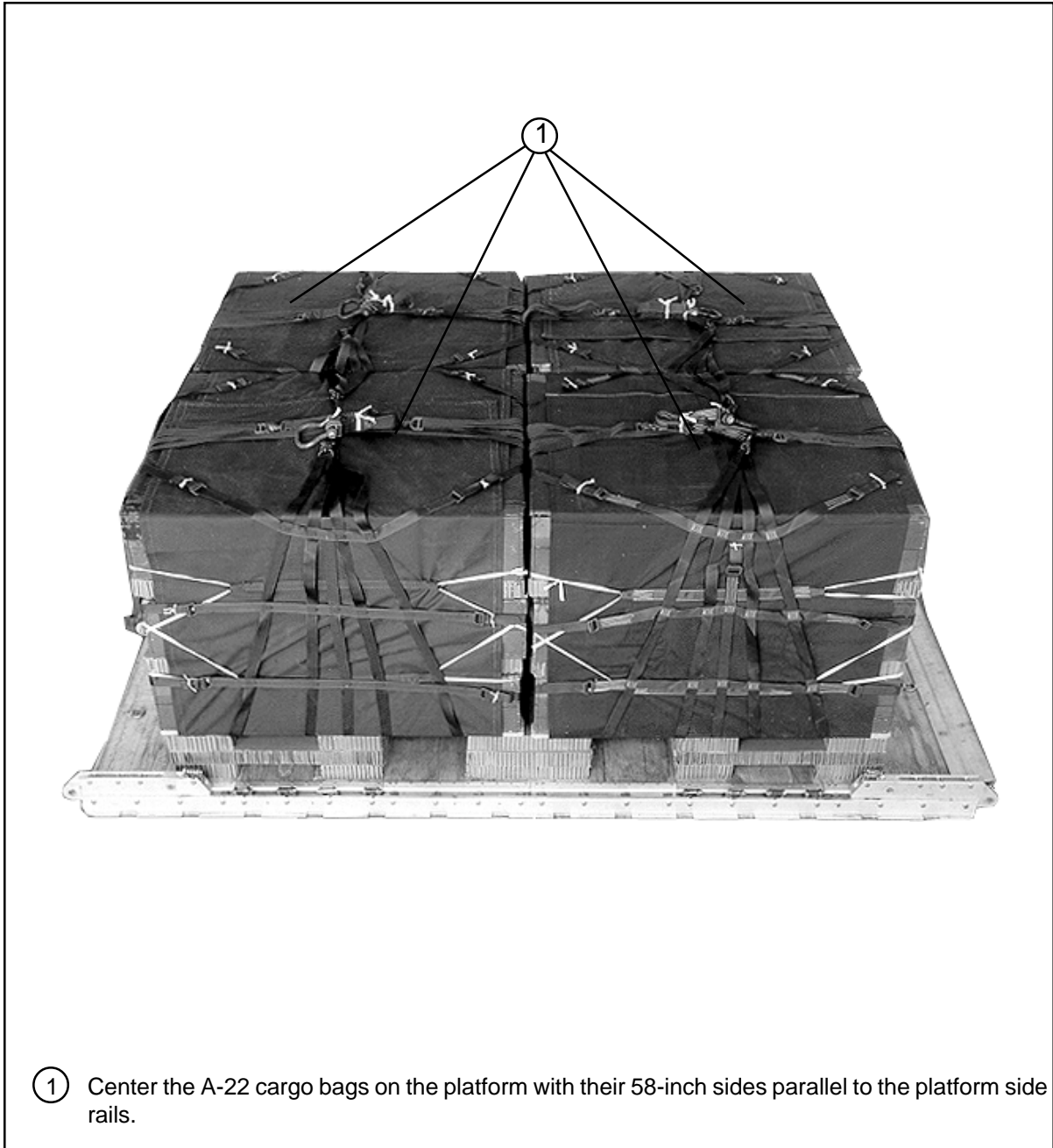
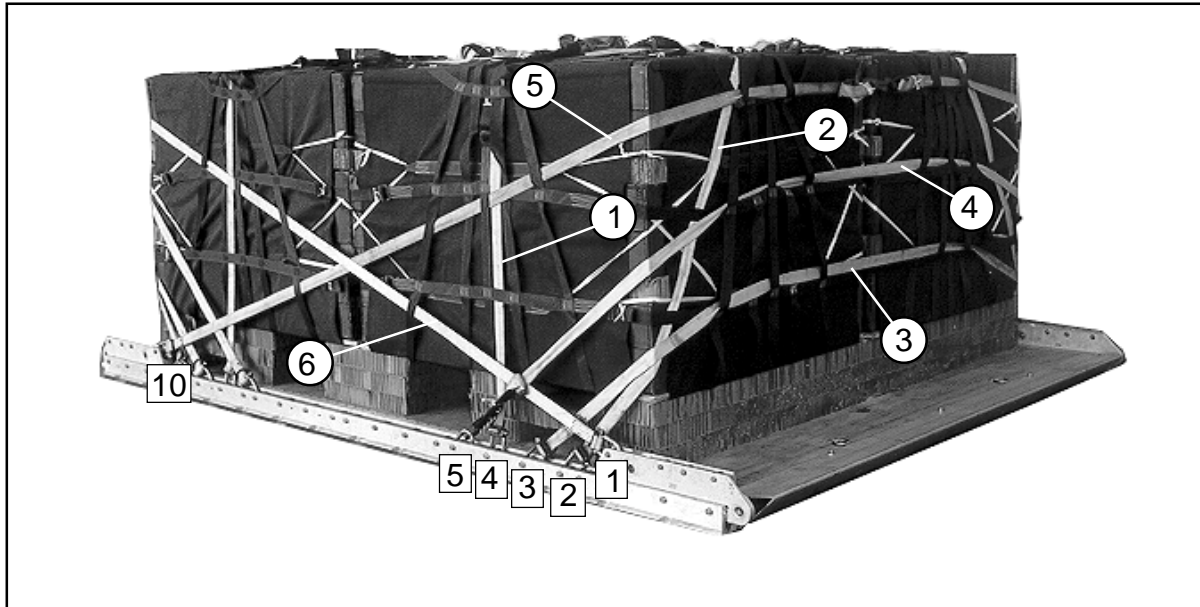

Figure 4-5. Missiles in A-22 Cargo Bags Positioned on Platform

LASHING LOAD

4-6. Lash the A-22 cargo bags to the platform as shown in Figures 4-6 and 4-7.



Lashing Number	Tie-down Clevis Numbers	Instructions
1	4 and 4A	Pass lashing: Through clevis 4 and through its own D-ring. Pass a second lashing through clevis 4A and its own D-ring. Pass the lashings over the top of the load (under the webbing) and through the medium clevis. Secure the lashings with two D-rings and a load binder on top of the load.
2	2 and 9A	Through clevis 2 and through its own D-ring. Pass a second lashing through clevis 9A and its own D-ring. Route the lashings over the load under the webbing. Secure the lashings on top of the load with two D-rings and a load binder.
3	3 and 3A	Through clevis 3 and its own D-ring. Pass the lashing around the front of the load under the webbing. Attach the lashing to clevis 3A with a D-ring and a load binder.
4	5 and 5A	Through clevis 5A and its own D-ring. Pass the lashing around the front of the load under the webbing. Attach the lashing to clevis 5 with a D-ring and a load binder.
5	10 and 10A	Through clevis 10 and through its own D-ring. Pass a second lashing through clevis 10A and its own D-ring. Pass the lashings around the front of the load under the webbing. Secure the lashings with two D-rings and a load binder.
6	1 and 1A	Through clevis 1 and through its own D-ring. Pass a second lashing through clevis 1A and its own D-ring. Pass the lashings around the rear of the load under the webbing. Secure the lashings with two D-rings and a load binder.

Figure 4-6. Lashings 1 Through 6 Installed

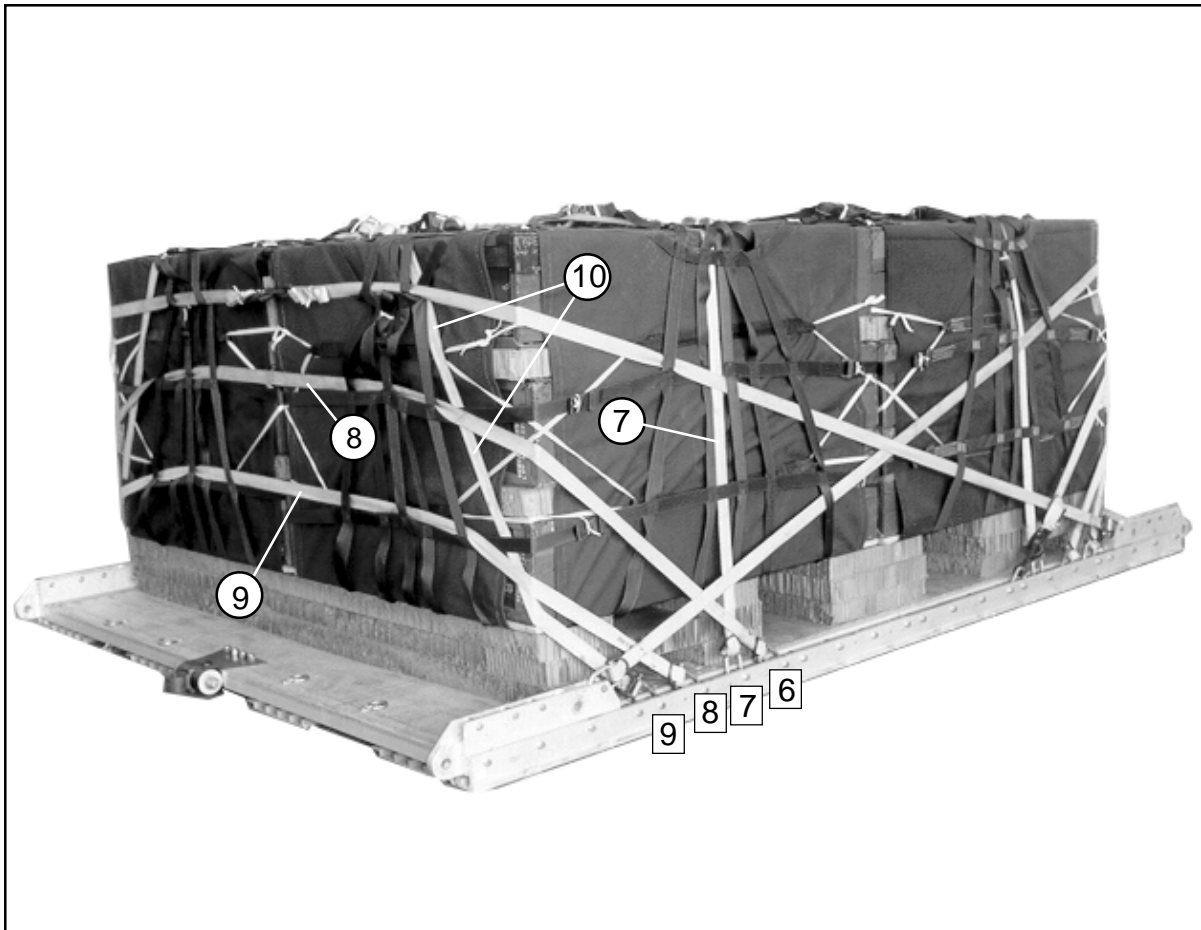

Lashing Number	Tie-down Clevis Numbers	Instructions
7	7 and 7A	Pass lashing: Through clevis 7 and its own D-ring. Pass a second lashing through clevis 7A and its own D-ring. Pass the lashings over the top of the load (under the webbing) and through the medium clevis. Secure the lashings with two D-rings and a load binder on top of the load.
8	6 and 6A	Through clevis 6 and its own D-ring. Pass the lashing around the rear of the load under the webbing. Attach the lashing to clevis 6A with a D-ring and a load binder.
9	8 and 8A	Through clevis 8 and its own D-ring. Pass the lashing around the rear of the load under the webbing. Attach the lashing to clevis 8A with a D-ring and a load binder.
10	9 and 2A	Through clevis 9 and its own D-ring. Pass a second lashing through clevis 2A and its own D-ring. Pass the lashings around the end and over the top of the load under the webbing. Secure the lashings with two D-rings and a load binder on top of the load.

Figure 4-7. Lashings 7 Through 10 Installed

INSTALLING SUSPENSION SLINGS

4-7. Install four 12-foot (2-loop), type XXVI nylon webbing slings as suspension slings. Install and safety the slings according to FM 10-500-2/TO 13C7-1-5, and as shown in Figure 4-8.

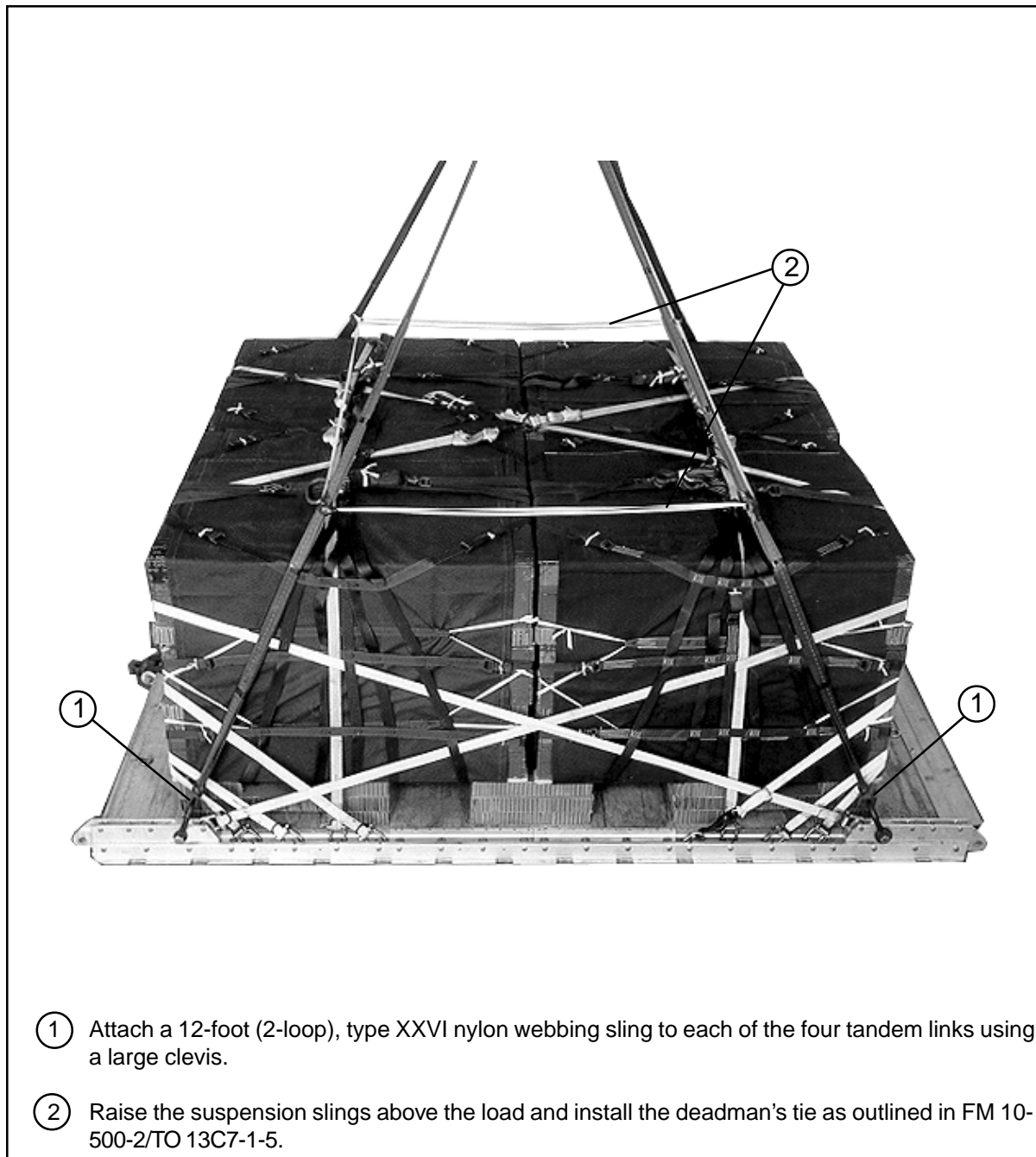

Figure 4-8. Suspension Slings Installed

INSTALLING CARGO PARACHUTES

4-8. Install two G-11 cargo parachutes according to FM 10-500-2/TO 13C7-1-5, and as shown in Figure 4-9.

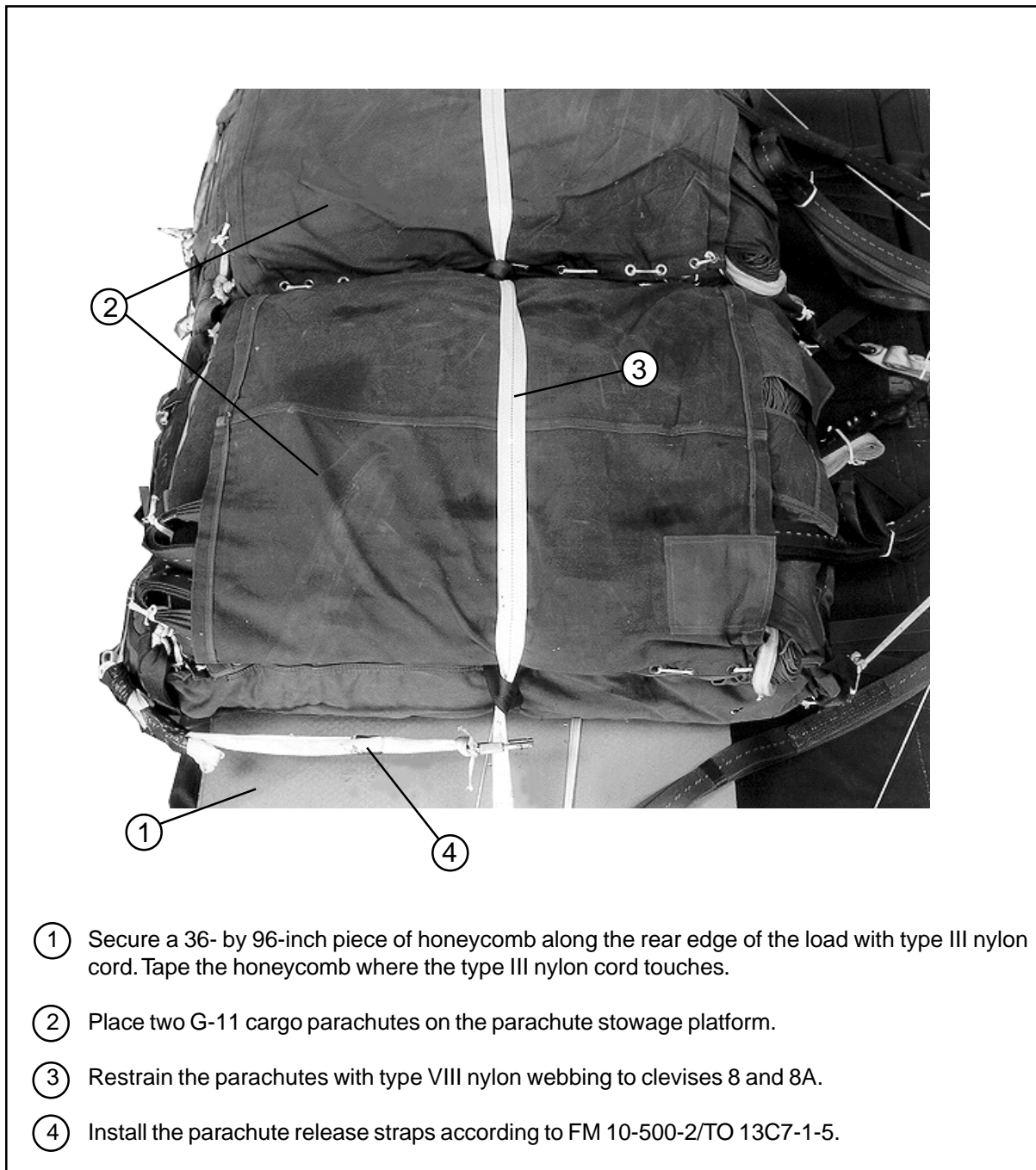
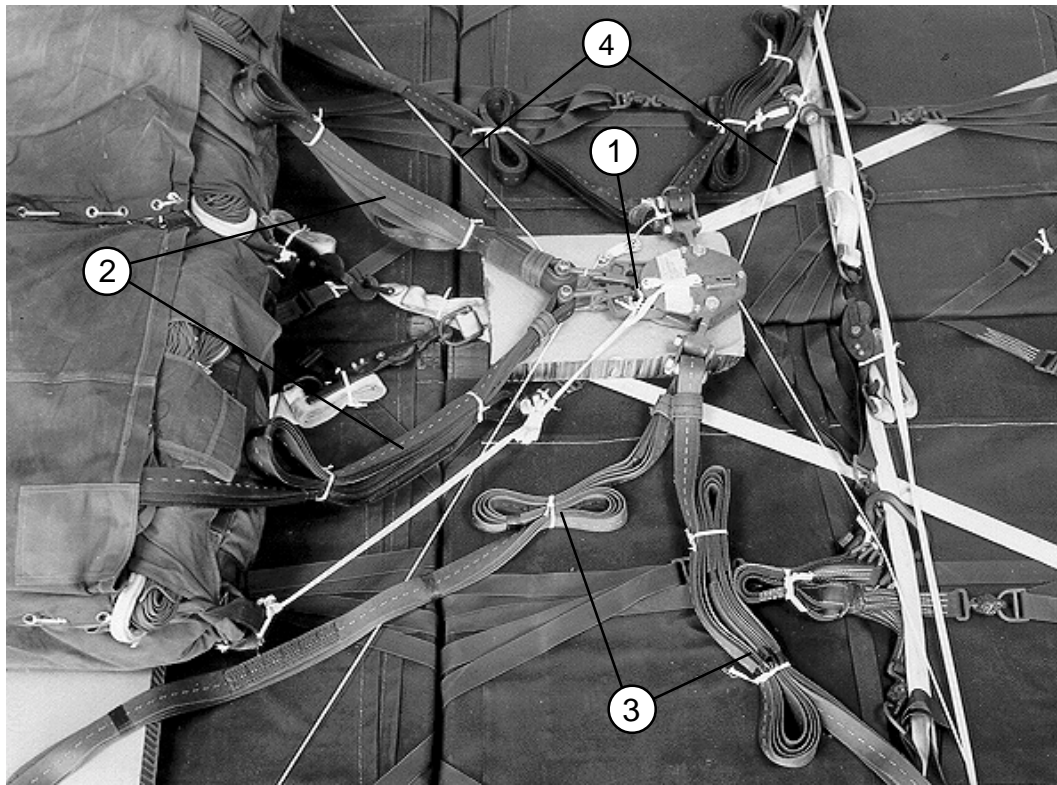

Figure 4-9. G-11 Cargo Parachutes Installed

Installing Release System

4-9. Install the M-1 cargo parachute release assembly according to FM 10-500-2/TO 13C7-1-5, and as shown in Figure 4-10.



- ① Center a piece of honeycomb on top of the load, and place an M-1 cargo parachute release on the honeycomb. Attach the parachute riser extension and suspension slings.
- ② Fold any excess parachute riser, and tie the folds with type I, 1/4-inch cotton webbing.
- ③ Fold any excess suspension sling, and tie the folds with type I, 1/4-inch cotton webbing.
- ④ Safety the release to the load with type III nylon cord.

Figure 4-10. M-1 Cargo Parachute Release Installed

Installing Extraction System

4-10. Install the EFTC extraction system according to FM 10-500-2/TO 13C7-1-5, and as shown in Figure 4-11.

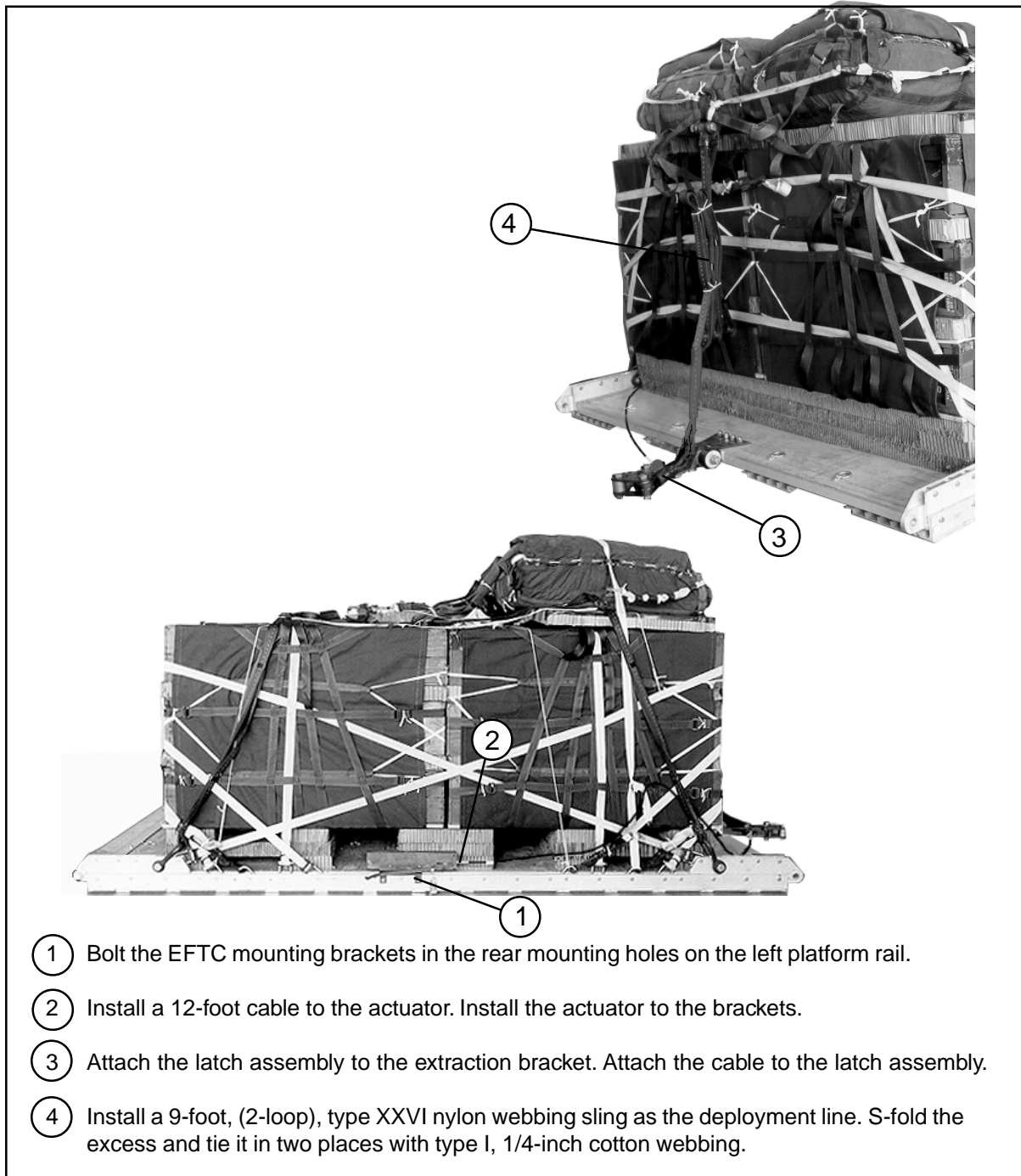

Figure 4-11. EFTC Installed

Installing Extraction Parachute

4-11. Select the extraction line and extraction parachute needed using the extraction line requirements table in FM 10-500-2/TO 13C7-1-5. Place the extraction parachute and extraction line on the load for installation in the aircraft.

Installing Provisions for Emergency Restraints

4-12. Select and install provisions for emergency restraints according to the emergency aft restraints requirements table in FM 10-500-2/TO 13C7-1-5.

Marking Rigged Load

4-13. Mark the rigged load according to FM 10-500-2/TO 13C7-1-5, and as shown in Figure 4-12. Complete the Shipper's Declaration for Dangerous Goods. If the load varies from the one shown, the weight, height, tip-off curve, CB, and parachute requirements must be recomputed.

Equipment Required

4-14. Use the equipment listed in Table 4-1 to rig this load.

**Make the final rigger inspection required by FM 10-500-2/
TO 13C7-1-5 before the load leaves the rigging site.**

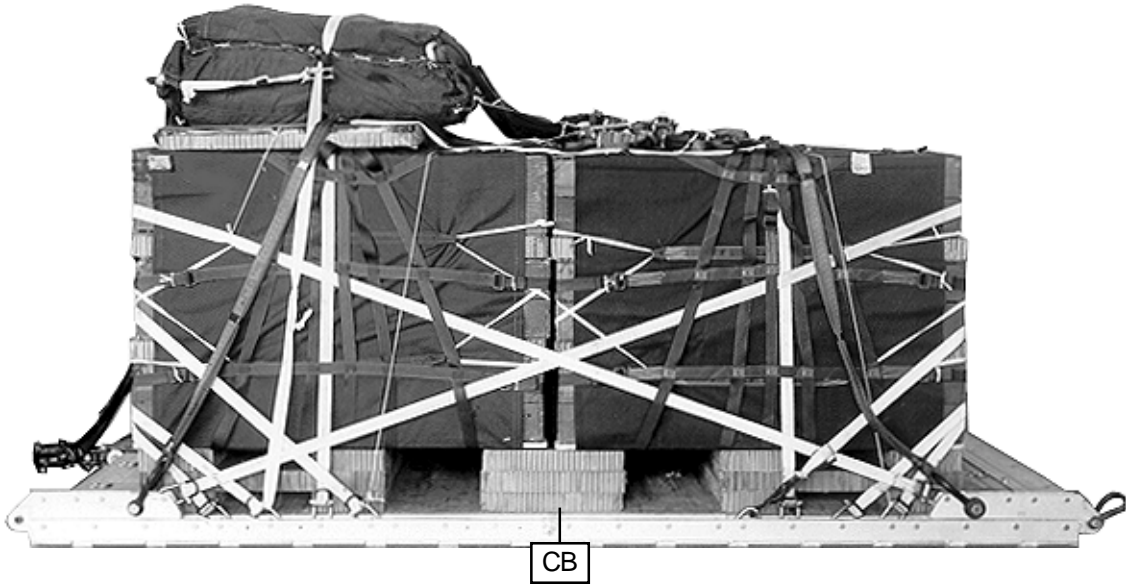

Rigged Load Data

Weight: Load shown	6,600 pounds
Maximum	7,100 pounds
Height	75 inches
Width	108 inches
Length	165 inches
Overhang: Front	0 inches
Rear	18 inches
CB (from front edge of platform)	77 inches
Extraction System (adds 18 inches to length of platform)	EFTC

Figure 4-12. TOW Missiles Rigged in A-22 Cargo Bags on a 12-foot Type V Platform for Low-velocity Airdrop

Table 4-1. Equipment Required for Rigging TOW Missiles in A-22 Cargo Bags on a 12-foot Type V Platform for Low-velocity Airdrop

National Stock Number	Item	Quantity
8040-00-273-8713	Adhesive paste, 1-gal	As required
1670-00-587-3421	Bag, cargo, A-22	4
4030-00-090-5354	Clevis, suspension, 1-in (large)	7
4030-00-678-8562	3/4-in, medium	6
4020-00-240-2146	Cord, nylon, type III, 550-lb	As required
1670-00-434-5783	Coupling, airdrop, extraction force transfer with cable, 12-ft	1
	Cover:	
1670-00-360-0328	Clevis, large	1
1670-00-360-0329	Link, type IV	3
1670-01-183-2678	Leaf, extraction line (line bag)	3
	Line, drogue (for C-17) 60-ft (1-loop), type XXVI	1
	Line, extraction	
1670-01-064-4452	For C-130: 60-ft (1-loop), type XXVI	1
1670-01-107-7652	For C-141: 160-ft (1-loop), type XXVI	1
	For C-5:	
1670-01-107-7652	160-ft (1-loop), type XXVI	1
1670-01-107-7652	For C-17: 160-ft (1-loop), type XXVI	1
	Link assembly:	
1670-00-783-5988	Type IV	3
	Two-point, 3 3/4-in (for C-17)	1
5306-00-435-8994	Bolt, 1-in diam, 4 in long	(2)
5310-00-232-5165	Nut, 1-in, hexagonal	(2)
1670-00-003-1953	Plate, side, 3 3/4-in	(2)
5365-00-007-3414	Spacer, large	(2)

Table 4-1. Equipment Required for Rigging TOW Missiles in A-22 Cargo Bags on a 12-foot Type V Platform for Low-velocity Airdrop (continued)

National Stock Number	Item	Quantity
1670-00-753-3928	Pad, energy-dissipating, honeycomb, 3- by 36- by 96-in	16 sheets
	Parachute:	
1670-01-016-7841	Cargo, G-11B	2
1670-01-063-3715	Cargo extraction, 15-ft	1
1670-01-063-3715	Drogue, 15-ft (for C-17)	1
	Platform, airdrop, type V, 12-ft	
1670-01-353-8425	Bracket assembly, coupling	(1)
1670-01-162-2372	Clevis assembly, type V	(20)
1670-01-354-8424	Extraction bracket assembly	(1)
1670-01-162-2381	Link, tandem, suspension link assembly	(4)
1670-01-097-8816	Release, cargo parachute, M-1	1
	Sling, cargo airdrop	
	For suspension:	
1670-01-062-6303	12-ft (2-loop), type XXVI nylon webbing	4
	For deployment:	
1670-01-062-6304	9-ft (2-loop), type XXVI nylon webbing	1
	For riser extension:	
1670-01-062-6302	20-ft (2-loop), type XXVI nylon webbing	2
1670-00-998-0116	Strap, parachute release, single or	1
5340-00-040-8219	Strap, parachute release, multicut	2
7510-00-266-5016	Tape, adhesive, 2-in	As required
1670-00-937-0271	Tie-down assembly, 15-ft	21
	Webbing:	
8305-00-268-2411	Cotton, 1/4-in, type I	As required
8305-00-082-5752	Nylon, tubular, 1/2-in	As required
8305-00-261-8585	Type VIII	As required

SECTION II- RIGGING MISSILES ON A TYPE V PLATFORM FOR LOW-VELOCITY AIRDROP

DESCRIPTION OF LOAD

4-15. Forty-eight boxed missiles are rigged on a 12-foot, type V airdrop platform. Each boxed missile weighs 87 pounds and is 57 1/2 inches long, 12 inches high, and 12 inches wide. This load requires two G-11 cargo parachutes.

PREPARING PLATFORM

- 4-16. Prepare a 12-foot, type V airdrop platform as described below.
- a. Inspecting Platform. Inspect, or, assemble and inspect, the platform according to TM 10-1670-268-20&P/TO 13C7-52-22.
 - b. Installing Tandem Links. Install tandem links as shown in Figure 4-13.
 - c. Attaching and Numbering Clevises. Attach and number 24 clevis assemblies as shown in Figure 4-13.

NOTES:

- 1. The nose bumper may or may not be installed.**
- 2. Measurements given in this load are from the front edge of the platform, NOT from the front edge of the nose bumper.**

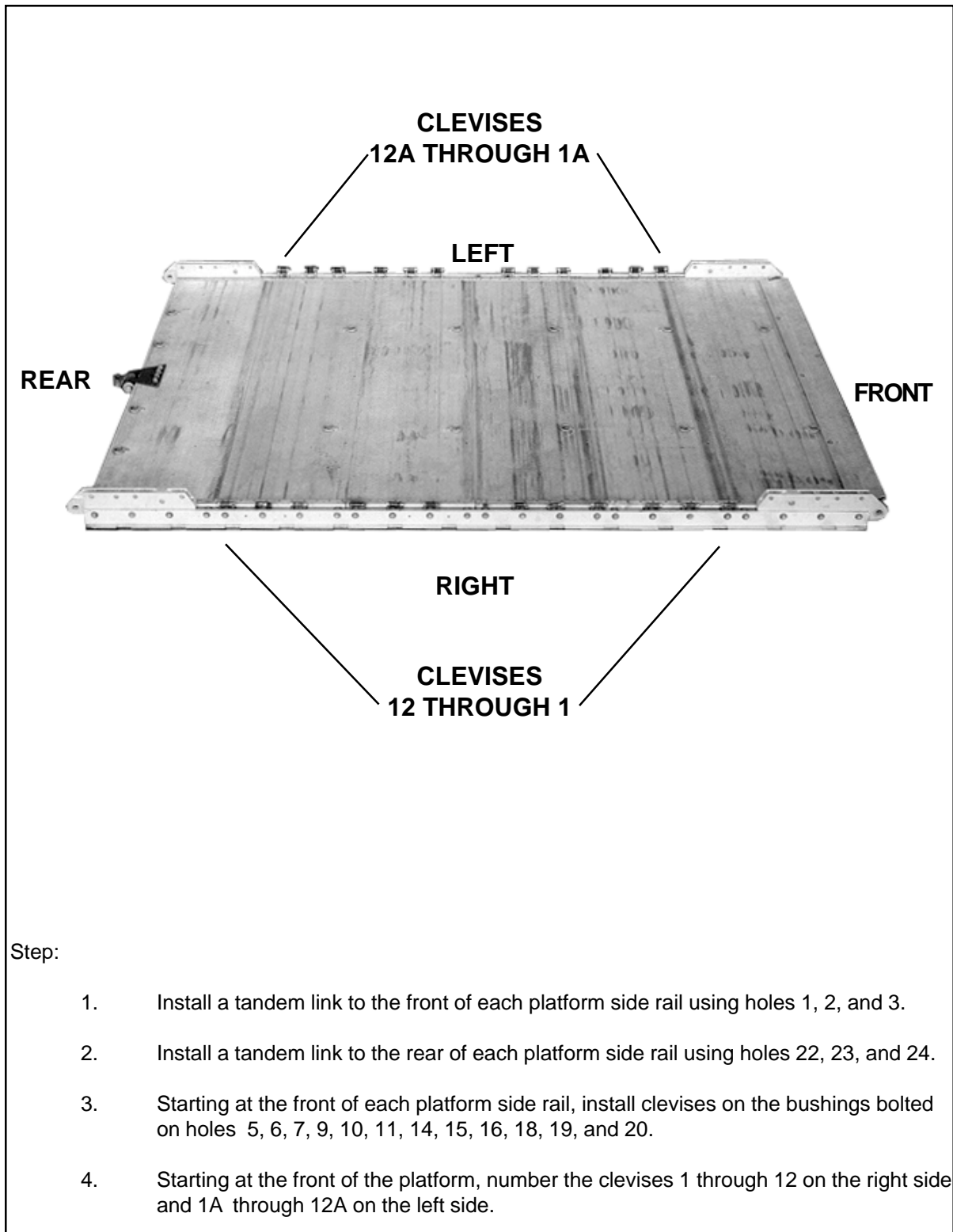

Step:

1. Install a tandem link to the front of each platform side rail using holes 1, 2, and 3.
2. Install a tandem link to the rear of each platform side rail using holes 22, 23, and 24.
3. Starting at the front of each platform side rail, install clevises on the bushings bolted on holes 5, 6, 7, 9, 10, 11, 14, 15, 16, 18, 19, and 20.
4. Starting at the front of the platform, number the clevises 1 through 12 on the right side and 1A through 12A on the left side.

Figure 4-13. Platform Prepared

BUILDING AND PLACING HONEYCOMB STACKS

4-17. Build the honeycomb stacks and place them on the platform as shown in Figure 4-14.

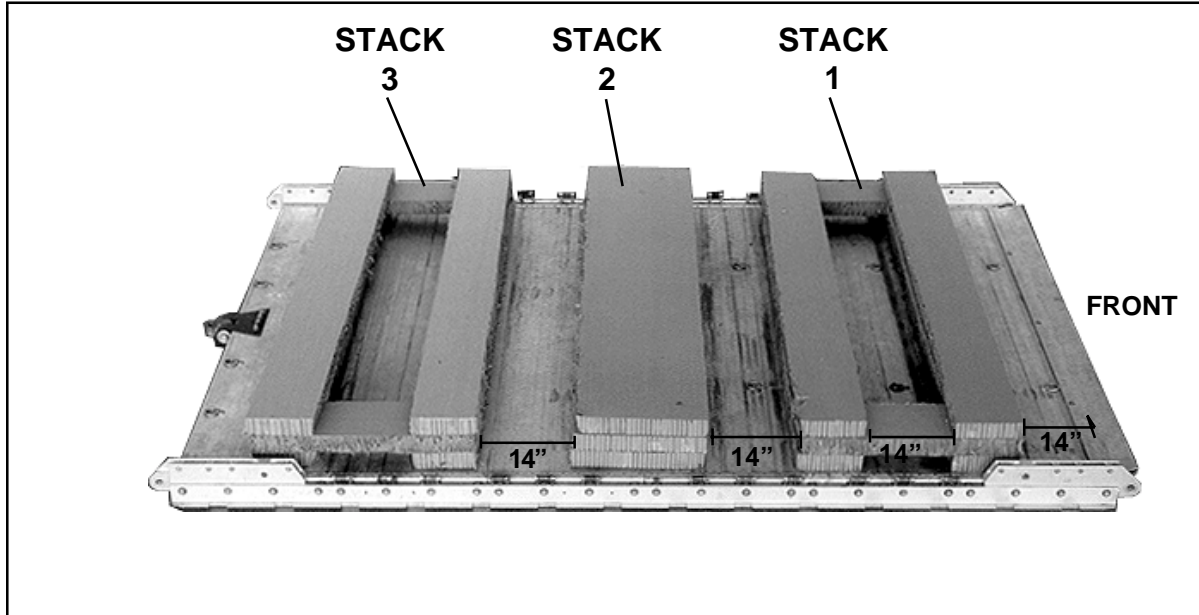

Stack Number	Pieces	Width (Inches)	Length (Inches)	Material	Instructions
1	2	96	10	Honeycomb	Place one piece 14 inches from the front edge of the platform. Place another piece 14 inches from the first piece.
	2	10	34	Honeycomb	Place one piece over each end of the two base pieces as a bridge.
	2	76	10	Honeycomb	Place flush over each base piece, filling the space between the two bridge pieces.
2	3	96	20	Honeycomb	Place flush over each end of the stack.
3	3	96	20	Honeycomb	Glue layers flush together and center 14 inches from stack 1.
	2	96	10	Honeycomb	Place one piece 14 inches from stack 2. Place another piece 14 inches from the first piece.
	2	10	34	Honeycomb	Place one piece over each end of the two base pieces as a bridge.
	2	76	10	Honeycomb	Place flush over each base piece, filling the space between the two bridge pieces.
	2	96	10	Honeycomb	Place flush over each end of the stack.

Figure 4-14. Honeycomb Stacks Prepared and Positioned

PLACING MISSILE BOXES ON PLATFORM

4-18. Place the missiles on the honeycomb stacks as shown in Figure 4-15. Place six 15-foot lashings over the stacks of boxes as shown in Figure 4-16.

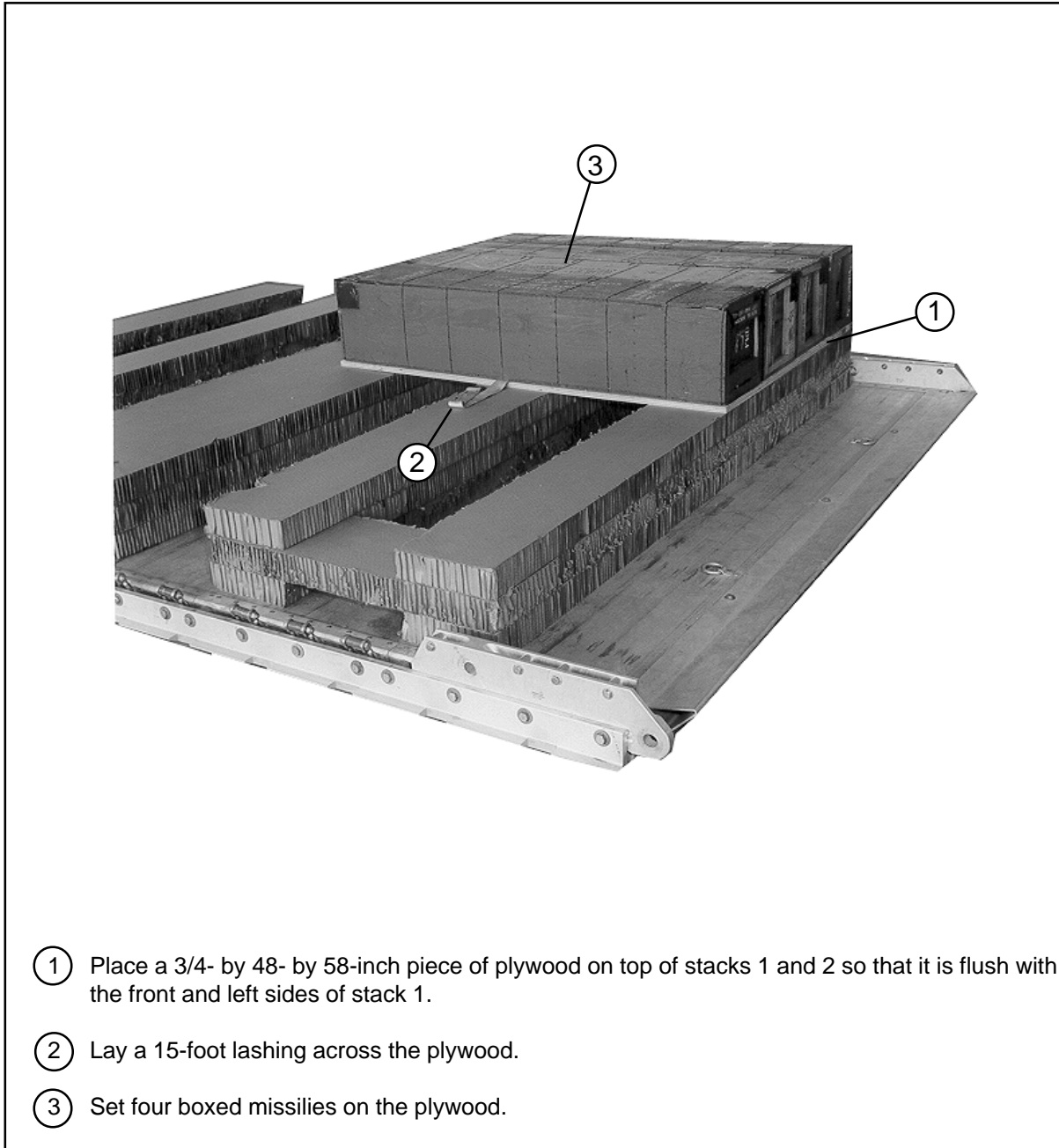
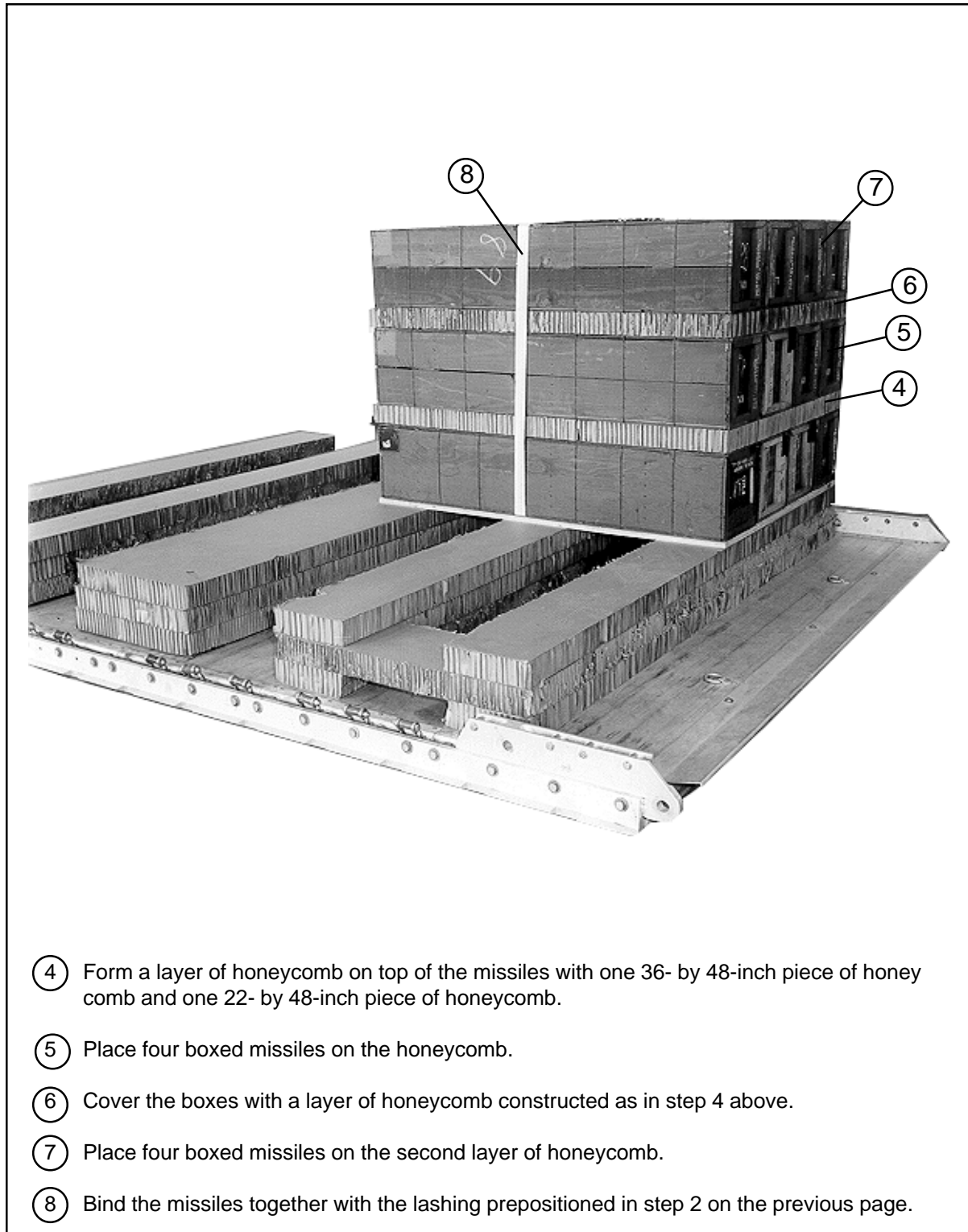
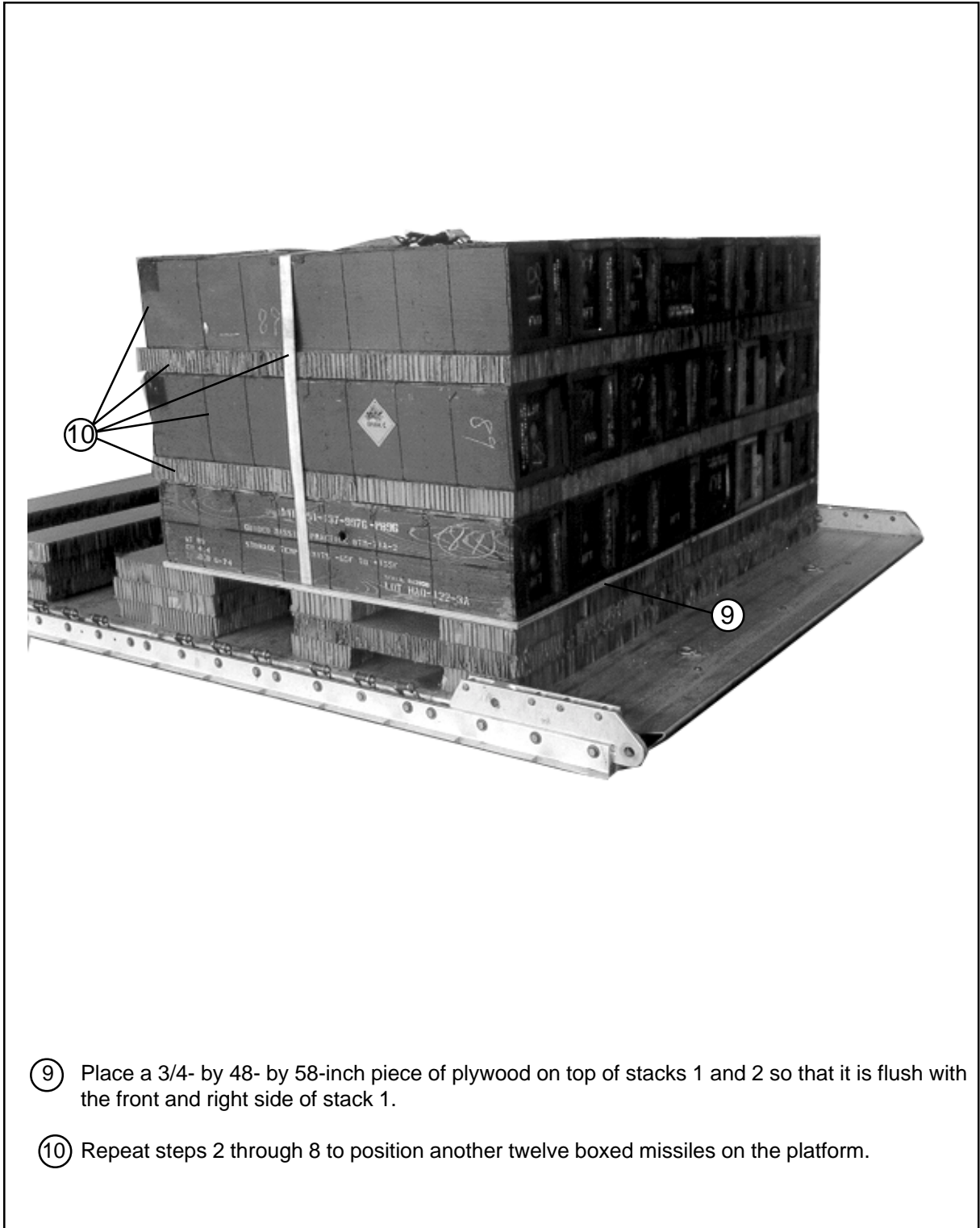

Figure 4-15. Missile Boxes Placed on Honeycomb



- ④ Form a layer of honeycomb on top of the missiles with one 36- by 48-inch piece of honeycomb and one 22- by 48-inch piece of honeycomb.
- ⑤ Place four boxed missiles on the honeycomb.
- ⑥ Cover the boxes with a layer of honeycomb constructed as in step 4 above.
- ⑦ Place four boxed missiles on the second layer of honeycomb.
- ⑧ Bind the missiles together with the lashing prepositioned in step 2 on the previous page.

Figure 4-15. Missile Boxes Placed on Honeycomb (continued)



- ⑨ Place a 3/4- by 48- by 58-inch piece of plywood on top of stacks 1 and 2 so that it is flush with the front and right side of stack 1.
- ⑩ Repeat steps 2 through 8 to position another twelve boxed missiles on the platform.

Figure 4-15. Missile Boxes Placed on Honeycomb (continued)

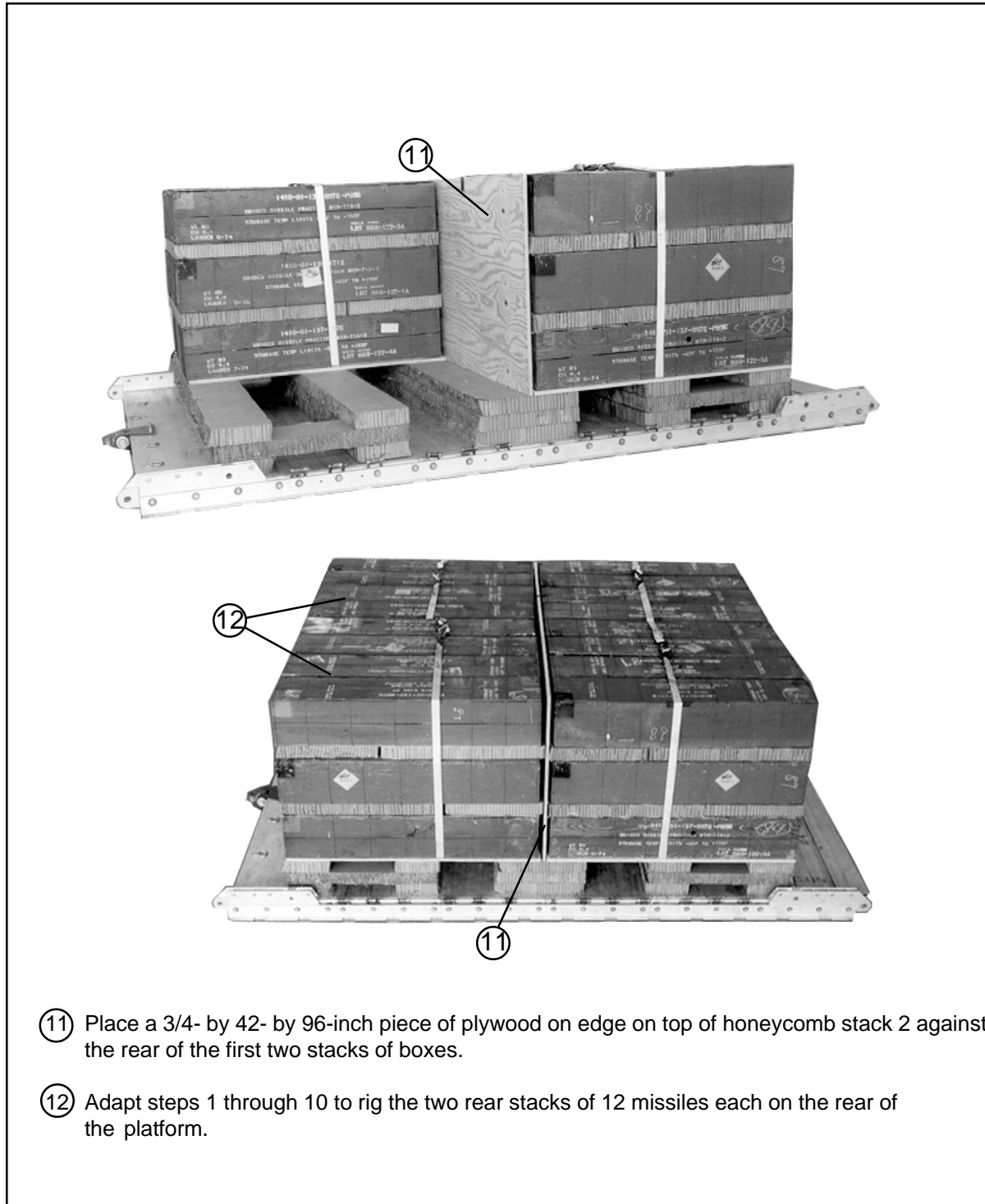

- ⑪ Place a 3/4- by 42- by 96-inch piece of plywood on edge on top of honeycomb stack 2 against the rear of the first two stacks of boxes.
- ⑫ Adapt steps 1 through 10 to rig the two rear stacks of 12 missiles each on the rear of the platform.

Figure 4-15. Missile Boxes Placed on Honeycomb (continued)

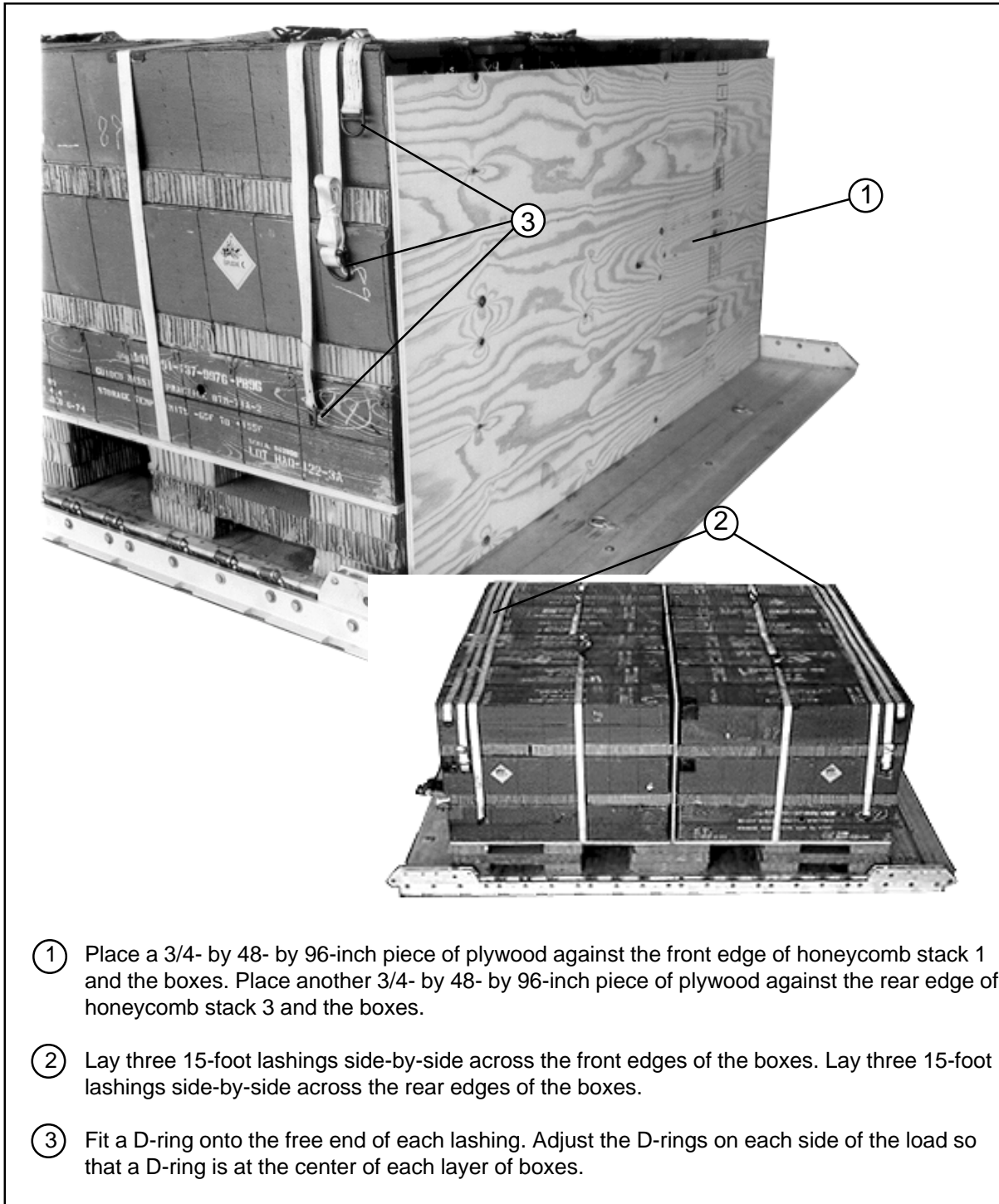
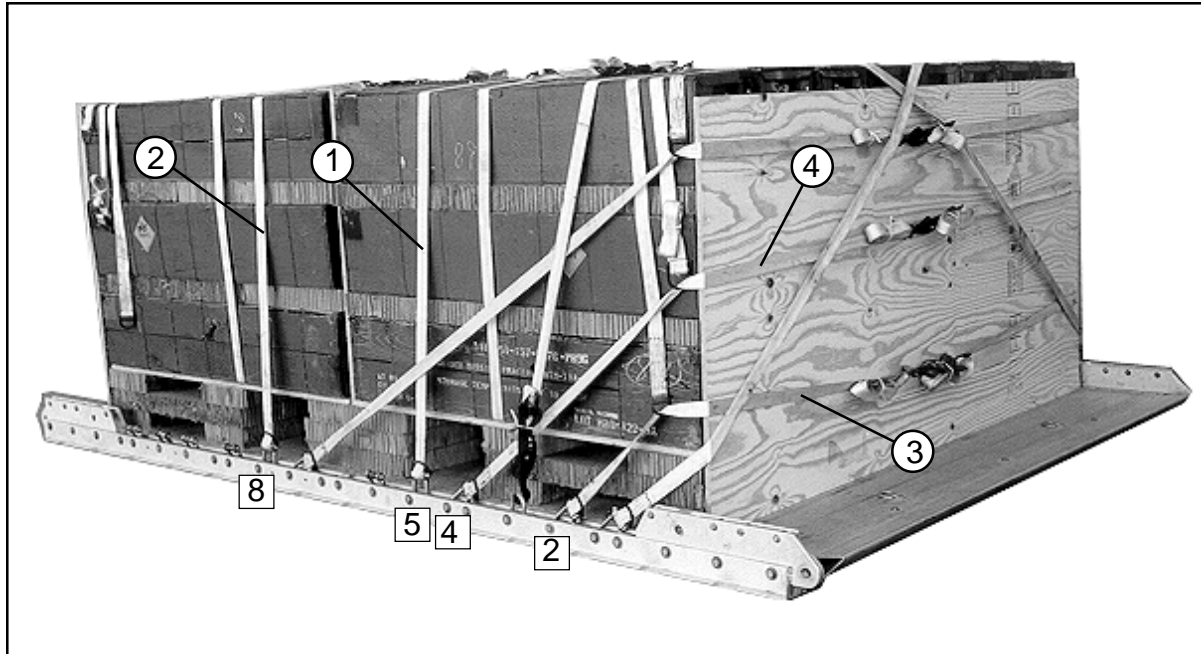

Figure 4-16. Lashings Placed on Missile Boxes

LASHING LOAD

4-19. Lash the A-22 cargo bags to the platform as shown in Figures 4-17 through 4-19. Secure the corner lashings as shown in Figure 4-20.



Lashing Number	Tie-down Clevis Numbers	Instructions
1	5 and 5A	Pass lashing: Through clevis 5 and its own D-ring. Pass a second lashing through clevis 5A and its own D-ring. Pass the lashings over the top of the load. Secure the lashings with two D-rings and a load binder on top of the load.
2	8 and 8A	Through clevis 8 and its own D-ring. Pass a second lashing through clevis 8A and its own D-ring. Pass the lashings over the top of the load. Secure the lashings with two D-rings and a load binder on top of the load.
3	2 and 2A	Through clevis 2 and its own D-ring. Pass a second lashing through clevis 2A and its own D-ring. Run each lashing through the D-ring at the bottom layer of boxes. Run each lashing to the front of the plywood. Secure the lashings in front with two D-rings and a load binder.
4	4 and 4A	Through clevis 4 and its own D-ring. Pass a second lashing through clevis 4A and its own D-ring. Run each lashing through the D-ring at the middle layer of boxes. Run each lashing to the front of the plywood. Secure the lashings in front with two D-rings and a load binder.

Figure 4-17. Lashings 1 Through 4 Installed

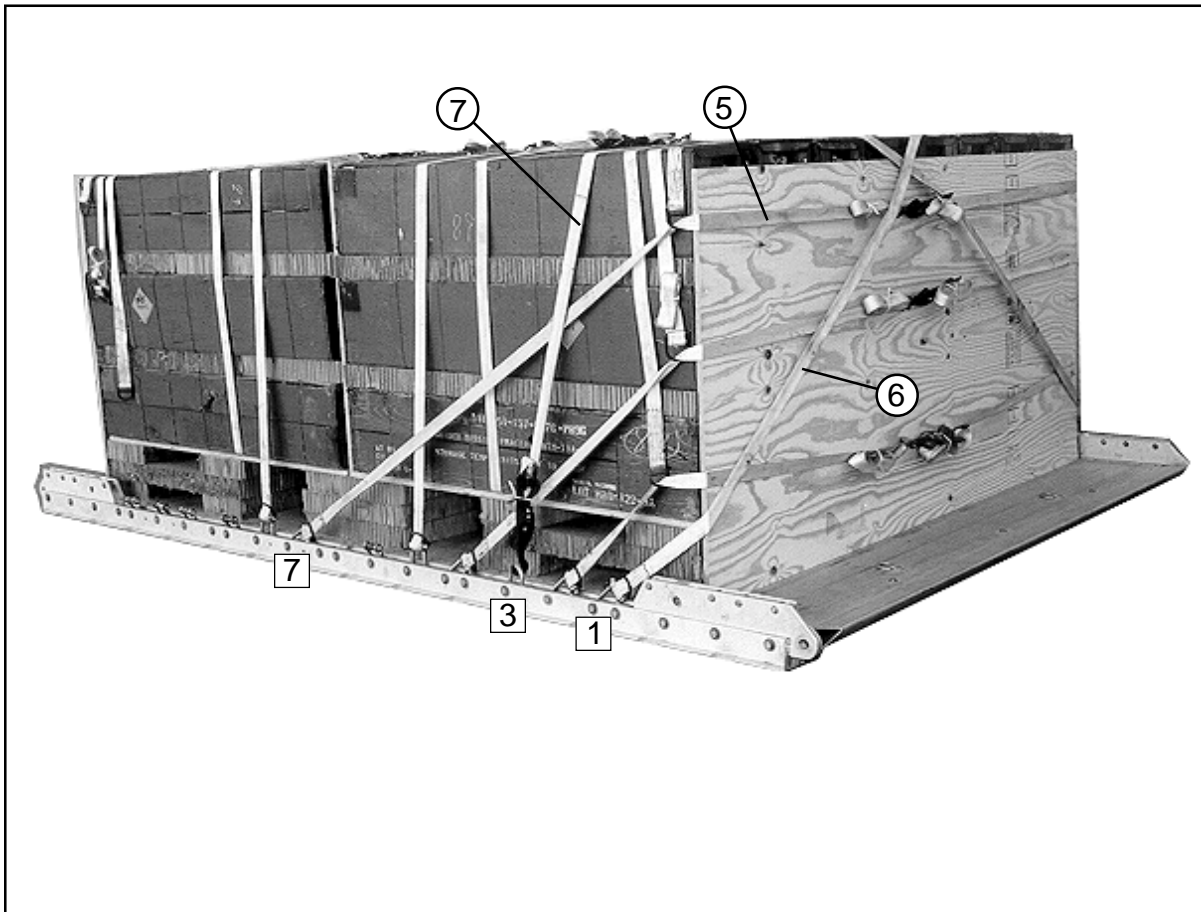

Lashing Number	Tie-down Clevis Numbers	Instructions
5	7 and 7A	Pass lashing: Through clevis 7 and its own D-ring. Pass a second lashing through clevis 7A and its own D-ring. Run each lashing through the D-ring at the top layer of boxes. Run each lashing to the front of the plywood. Secure the lashings in front with two D-rings and a load binder.
6	1 and 3A	Through clevis 1 and through its own D-ring. Run the lashing around the front of the plywood and over the top of the boxes. Attach a D-ring to the free end of the lashing and secure it to clevis 3A with a load binder.
7	1A and 3	Through clevis 1A and through its own D-ring. Run the lashing around the front of the plywood and over the top of the boxes. Attach a D-ring to the free end of the lashing and secure it to clevis 3 with a load binder.

Figure 4-18. Lashings 5 Through 7 Installed

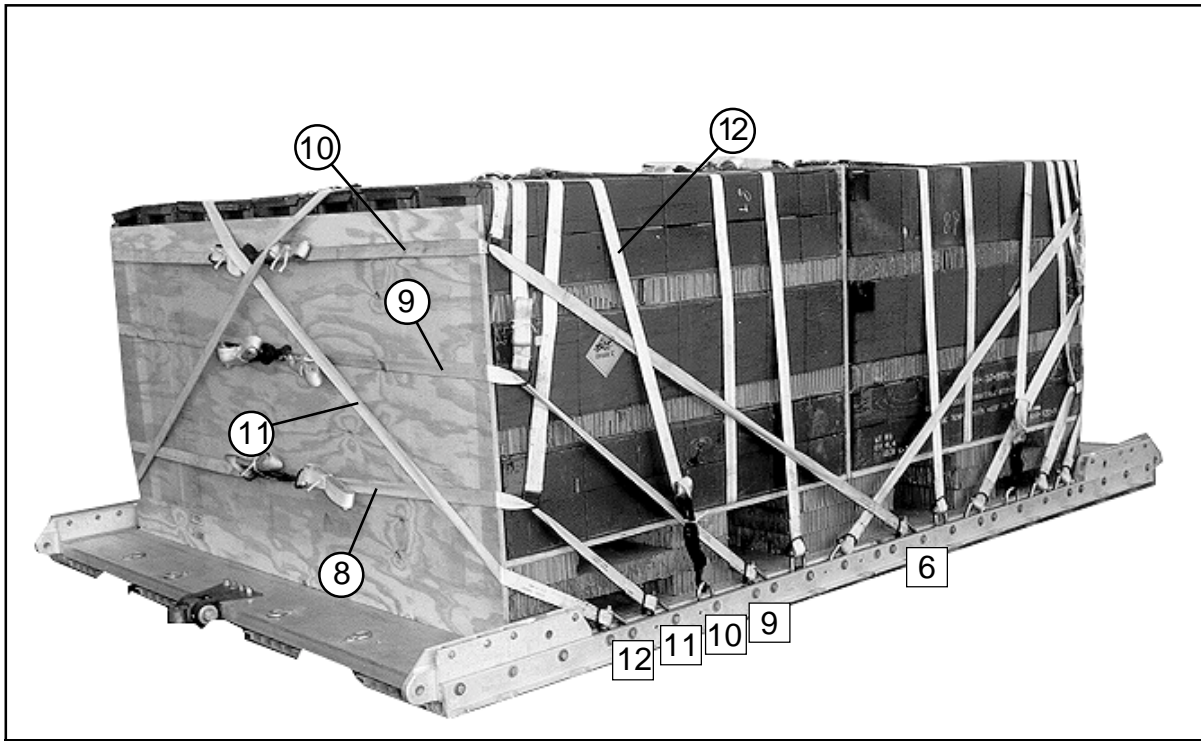

Lashing Number	Tie-down Clevis Numbers	Instructions
8	11 and 11A	Pass lashing: Through clevis 11 and its own D-ring. Pass a second lashing through clevis 11A and its own D-ring. Run each lashing through the D-ring at the bottom layer of boxes. Run each lashing to the rear of the plywood. Secure the lashings in the rear with two D-rings and a load binder.
9	9 and 9A	Through clevis 9 and its own D-ring. Pass a second lashing through clevis 9A and its own D-ring. Run each lashing through the D-ring at the middle layer of boxes. Run each lashing to the rear of the plywood. Secure the lashings in the rear with two D-rings and a load binder.
10	6 and 6A	Through clevis 6 and its own D-ring. Pass a second lashing through clevis 6A and its own D-ring. Run each lashing through the D-ring at the top layer of boxes. Run each lashing to the rear of the plywood. Secure the lashings in the rear with two D-rings and a load binder.
11	12 and 10A	Through clevis 12 and through its own D-ring. Run the lashing around the rear of the plywood and over the top of the boxes. Attach a D-ring to the free end of the lashing and secure it to clevis 10A with a load binder.
12	10 and 12A	Through clevis 12A and through its own D-ring. Run the lashing around the rear of the plywood and over the top of the boxes. Attach a D-ring to the free end of the lashing and secure it to clevis 10 with a load binder.

Figure 4-19. Lashings 8 Through 12 Installed

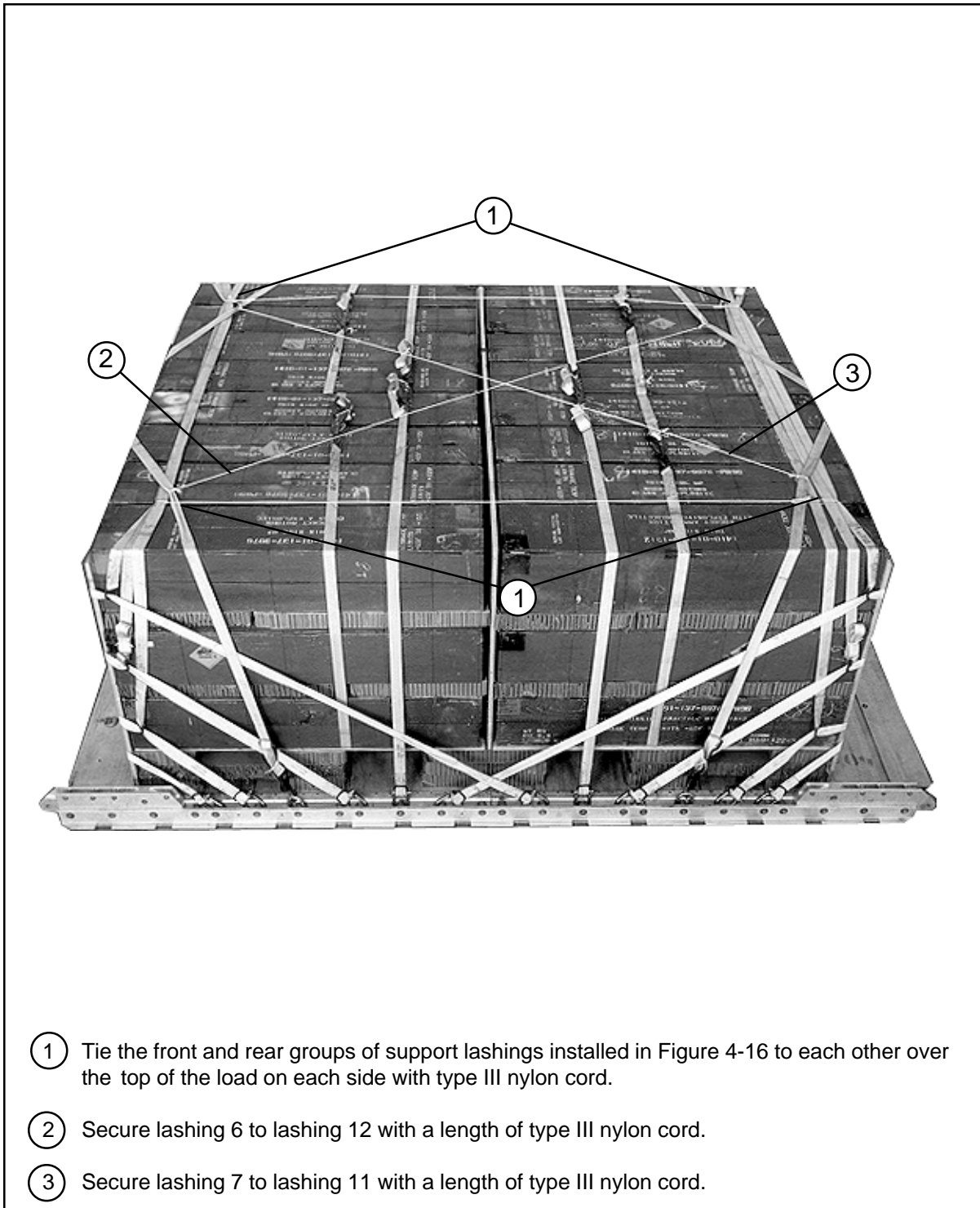

- ① Tie the front and rear groups of support lashings installed in Figure 4-16 to each other over the top of the load on each side with type III nylon cord.
- ② Secure lashing 6 to lashing 12 with a length of type III nylon cord.
- ③ Secure lashing 7 to lashing 11 with a length of type III nylon cord.

Figure 4-20. Lashings Secured

INSTALLING SUSPENSION SLINGS

4-20. Install four 12-foot (2-loop), type XXVI nylon webbing slings as suspension slings. Install and safety the slings according to FM 10-500-2/TO 13C7-1-5, and as shown in Figure 4-21.

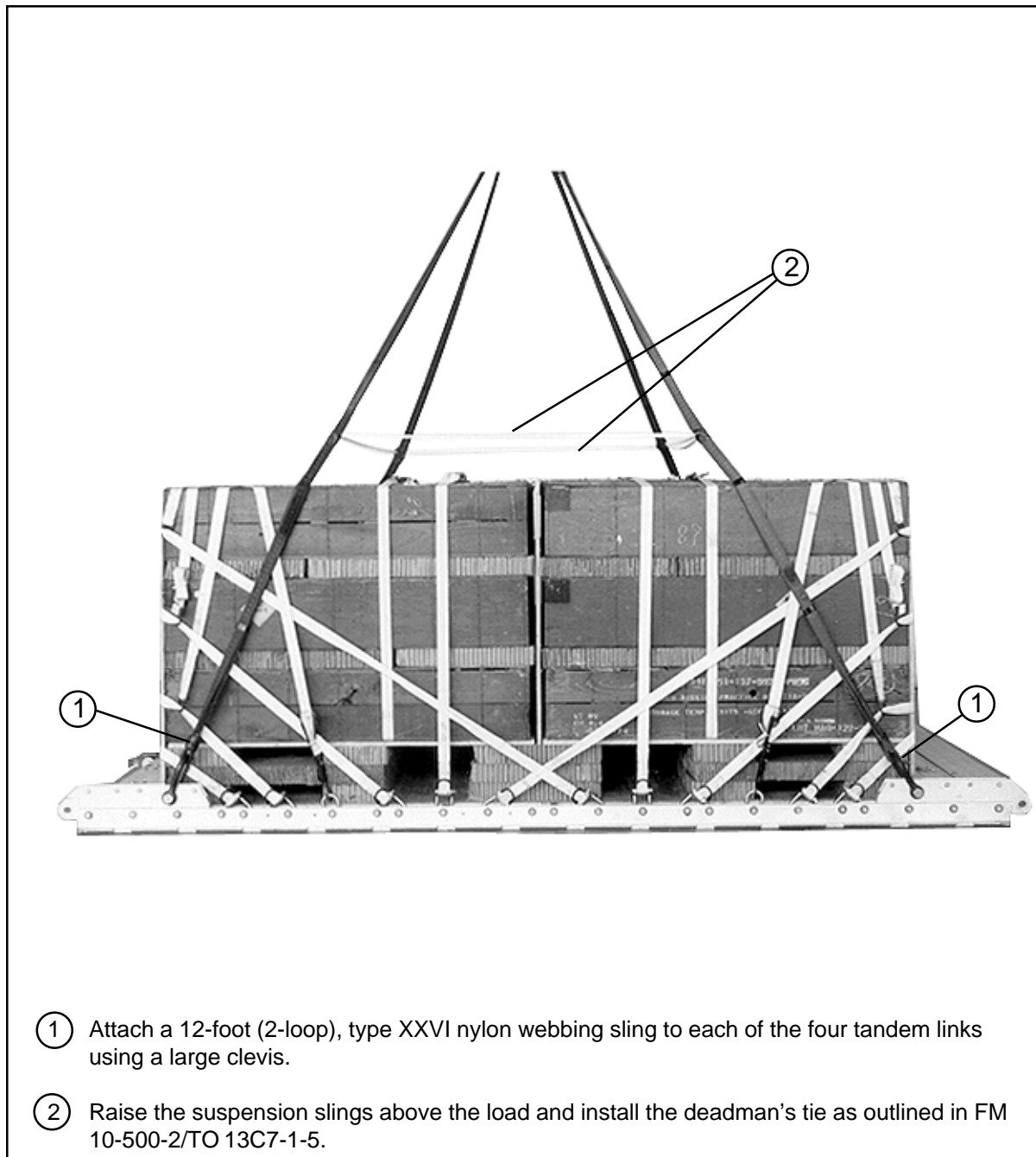

Figure 4-21. Suspension Slings Installed

INSTALLING CARGO PARACHUTES

4-21. Install two G-11 cargo parachutes according to FM 10-500-2/TO 13C7-1-5, and as shown in Figure 4-22.

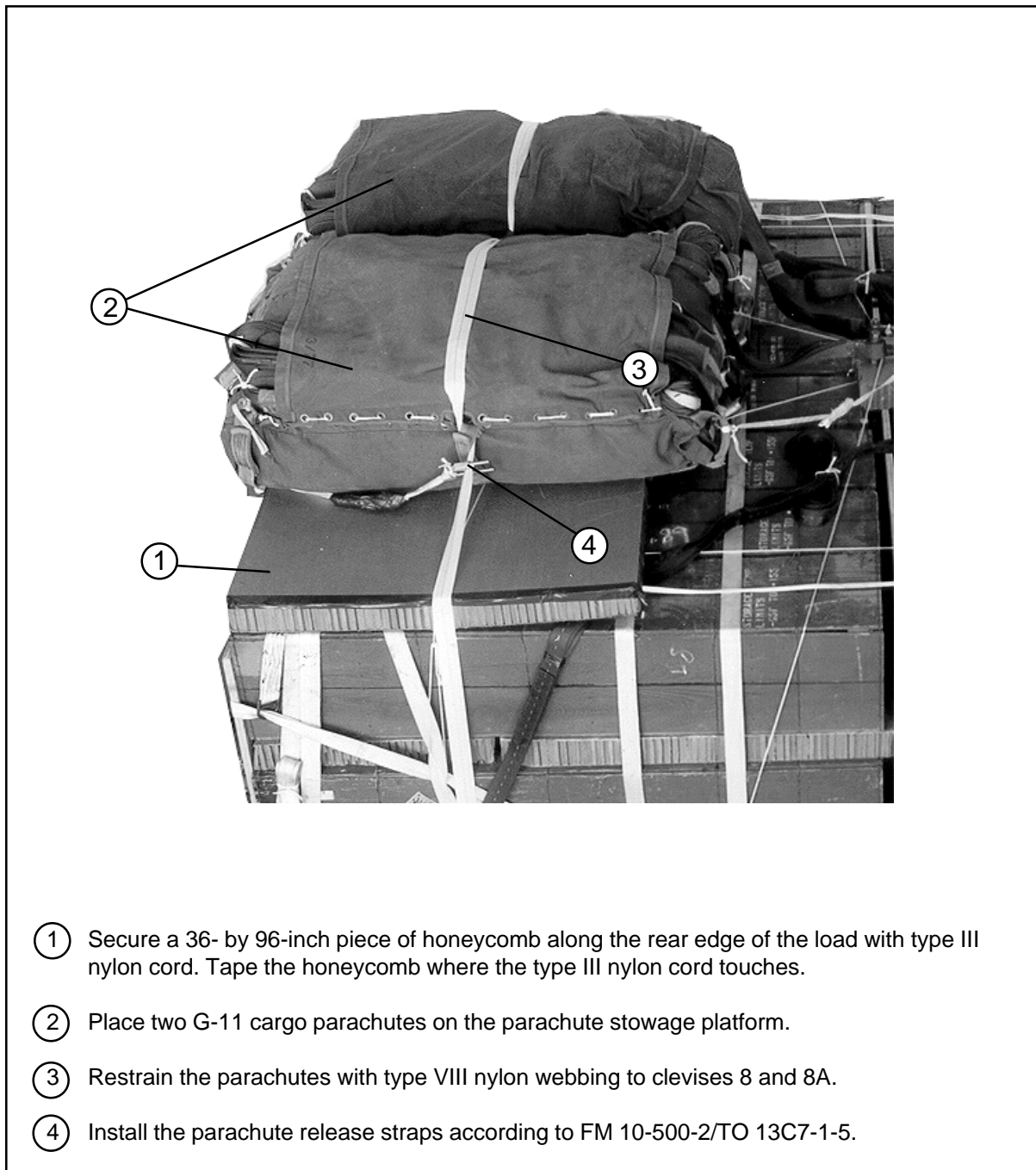

Figure 4-22. G-11 Cargo Parachutes Installed

Installing Release System

4-22. Install the M-1 cargo parachute release assembly according to FM 10-500-2/TO 13C7-1-5, and as shown in Figure 4-23.

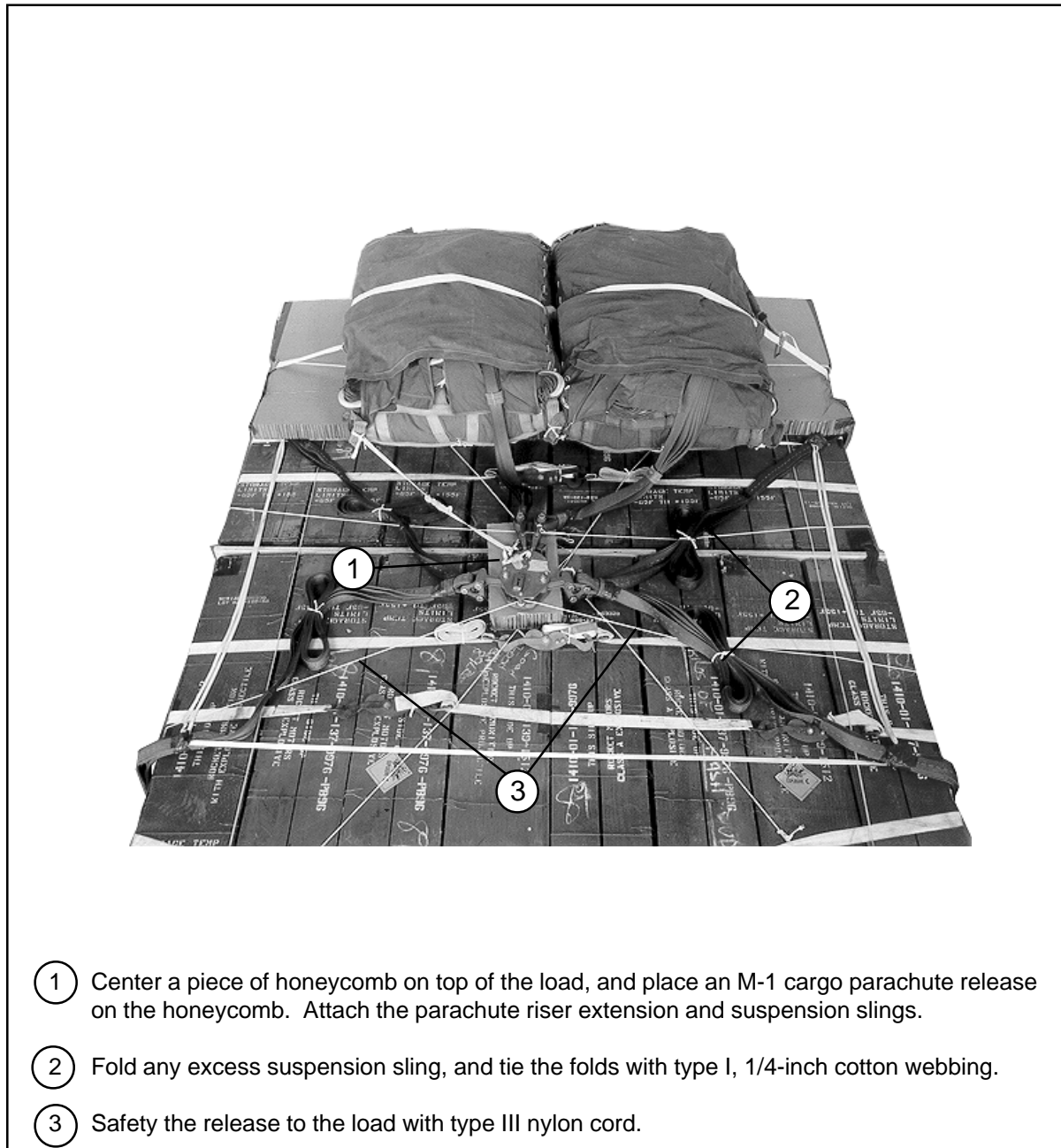

Figure 4-23. M-1 Cargo Parachute Release Installed

Installing Extraction System

4-23. Install the EFTC extraction system according to FM 10-500-2/TO 13C7-1-5, and as shown in Figure 4-11. Use the front mounting holes in the left platform side rail to install the EFTC actuator mounting brackets. Install a 12-foot cable, and a 9-foot, (2-loop), type XXVI sling as a deployment line.

Installing Extraction Parachute

4-24. Select the extraction line and extraction parachute needed using the extraction line requirements table in FM 10-500-2/TO 13C7-1-5. Place the extraction parachute and extraction line on the load for installation in the aircraft.

Installing Provisions for Emergency Restraints

4-25. Select and install provisions for emergency restraints according to the emergency aft restraints requirements table in FM 10-500-2/TO 13C7-1-5.

Marking Rigged Load

4-26. Mark the rigged load according to FM 10-500-2/TO 13C7-1-5, and as shown in Figure 4-24. Complete the Shipper's Declaration for Dangerous Goods. If the load varies from the one shown, the weight, height, tip-off curve, CB, and parachute requirements must be recomputed.

Equipment Required

4-27. Use the equipment listed in Table 4-2 to rig this load.

**Make the final rigger inspection required by FM 10-500-2/
TO 13C7-1-5 before the load leaves the rigging site.**

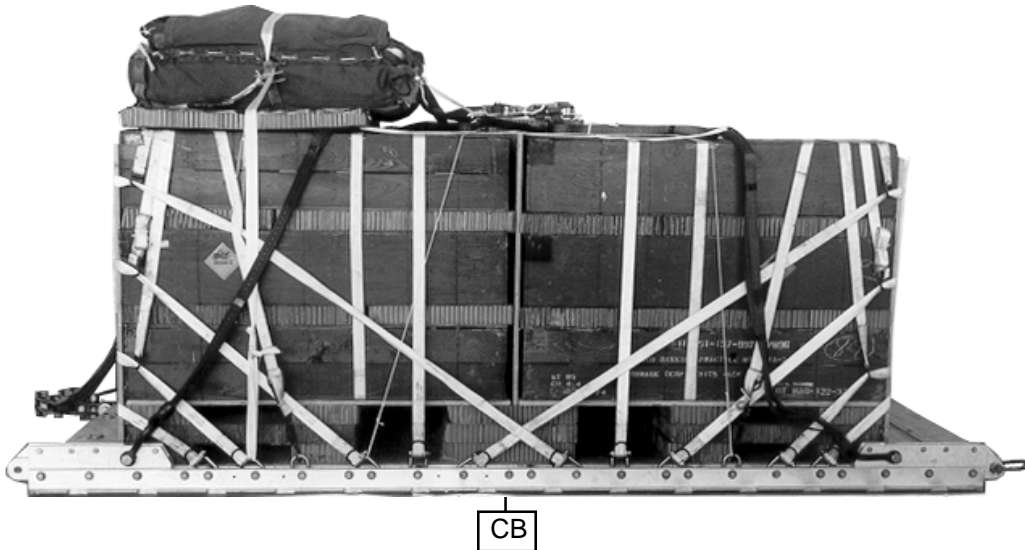

Rigged Load Data

Weight: Load shown	6,650 pounds
Maximum	7,100 pounds
Height	75 inches
Width	108 inches
Length	165 inches
Overhang: Front	0 inches
Rear	18 inches
CB (from front edge of platform)	77 inches
Extraction System (adds 18 inches to length of platform)	EFTC

Figure 4-24. TOW Missiles Rigged on a 12-foot Type V Platform for Low-velocity Airdrop

Table 4-2. Equipment Required for Rigging TOW Missiles on a 12-foot Type V Platform for Low-velocity Airdrop

National Stock Number	Item	Quantity
8040-00-273-8713	Adhesive paste, 1-gal	As required
	Clevis, suspension,	
4030-00-090-5354	1-in (large)	7
4030-00-678-8562	3/4-in, medium	2
4020-00-240-2146	Cord, nylon, type III, 550-lb	As required
1670-00-434-5783	Coupling, airdrop, extraction force transfer with cable, 12-ft	1
	Cover:	
1670-00-360-0328	Clevis, large	3
1670-00-360-0329	Link, type IV	3
1670-01-183-2678	Leaf, extraction line (line bag)	3
	Line, drogue (for C-17)	
1670-01-064-4452	60-ft (1-loop), type XXVI	1
	Line, extraction	
1670-01-064-4452	For C-130: 60-ft (1-loop), type XXVI	1
1670-01-107-7652	For C-141: 160-ft (1-loop), type XXVI	1
	For C-5:	
1670-01-107-7652	160-ft (1-loop), type XXVI	1
1670-01-107-7652	For C-17: 160-ft (1-loop), type XXVI	1
	Link assembly:	
1670-00-783-5988	Type IV	3
	Two-point, 3 3/4-in (for C-17)	1
5306-00-435-8994	Bolt, 1-in diam, 4 in long	(2)
5310-00-232-5165	Nut, 1-in, hexagonal	(2)
1670-00-003-1953	Plate, side, 3 3/4-in	(2)
5365-00-007-3414	Spacer, large	(2)

Table 4-2. Equipment Required for Rigging TOW Missiles on a 12-foot Type V Platform for Low-velocity Airdrop (continued)

National Stock Number	Item	Quantity
1670-00-753-3928	Pad, energy-dissipating, honeycomb, 3- by 36- by 96-in	18 sheets
1670-01-016-7841	Parachute: Cargo, G-11B	2
1670-01-063-3715	Cargo extraction, 15-ft	1
1670-01-063-3715	Drogue, 15-ft (for C-17)	1
1670-01-353-8425	Platform, airdrop, type V, 12-ft Bracket assembly, coupling	(1)
1670-01-162-2372	Clevis assembly, type V	(24)
1670-01-354-8424	Extraction bracket assembly	(1)
1670-01-162-2381	Link, tandem, suspension link assembly	(4)
5530-00-128-4981	Plywood, 3/4- by 48- by 96-in	7 sheets
1670-01-097-8816	Release, cargo parachute, M-1	1
1670-01-062-6303	Sling, cargo airdrop For suspension: 12-ft (2-loop), type XXVI nylon webbing	4
1670-01-062-6304	For deployment: 9-ft (2-loop), type XXVI nylon webbing	1
1670-01-062-6302	For riser extension: 20-ft (2-loop), type XXVI nylon webbing	2
1670-00-998-0116	Strap, parachute release, single or	1
5340-00-040-8219	Strap, parachute release, multicut	2
7510-00-266-5016	Tape, adhesive, 2-in	As required
1670-00-937-0271	Tie-down assembly, 15-ft	30
8305-00-268-2411	Webbing: Cotton, 1/4-in, type I	As required
8305-00-082-5752	Nylon, tubular, 1/2-in	As required
8305-00-261-8585	Type VIII	As required

Chapter 5

Rigging the Improved Target Acquisition System (ITAS) in M1121 HMMWV Truck for Low-velocity Airdrop

DESCRIPTION OF LOAD

5-1. The ITAS is an aiming system for the TOW missile. Another aiming system is shown in Chapter 6. The ITAS consists of the Fire Control Subsystem (FCS), Traversing Unit (TU), Target Acquisition Subsystem (TAS), and Battery Power Source (BPS). Rig the ITAS in the M1121 or M966 HMMWV truck as shown in this chapter. Use FM 10-517/TO 13C7-1-111 to rig the truck on a 16-foot, type V airdrop platform.

PREPARING PLATFORM, HONEYCOMB, AND TRUCK

5-2. Prepare the platform, three honeycomb stacks, and the M966 or M1211 truck as shown in Chapters 2 and 3 of FM 10-517/TO 13C7-1-111.

a. Inspect, assemble, and install clevises on a 16-foot, type V airdrop platform according to TM 10-1670-268-20&P/TO 13C7-52-22, and as shown in Figure 2-2, FM 10-517/TO 13C7-1-111.

b. Prepare three honeycomb stacks as shown in Figures 2-3 and 2-4, FM 10-517/TO 13C7-1-111.

c. Prepare the truck as shown in Figures 3-2 and 3-3, FM 10-517/TO 13C7-1-111.

RIGGING ITAS IN HMMWV TRUCK

5-3. Rig the components of the ITAS in the truck as shown in Figure 5-1.

COMPLETING THE LOAD

5-4. Finish rigging the M966 or M1121 HMMWV truck as shown in Chapter 3, FM 10-517/TO 13C7-1-111.

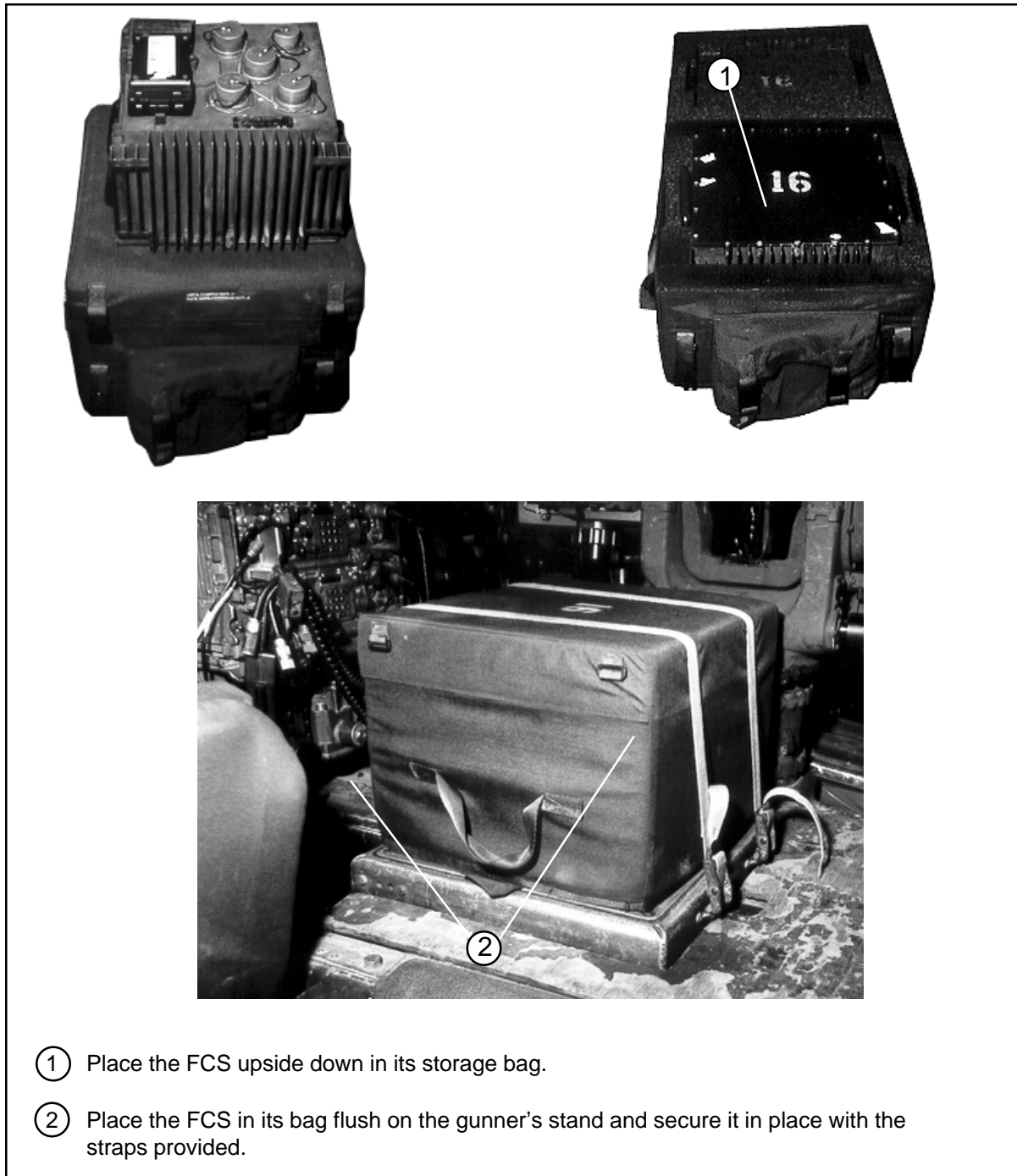
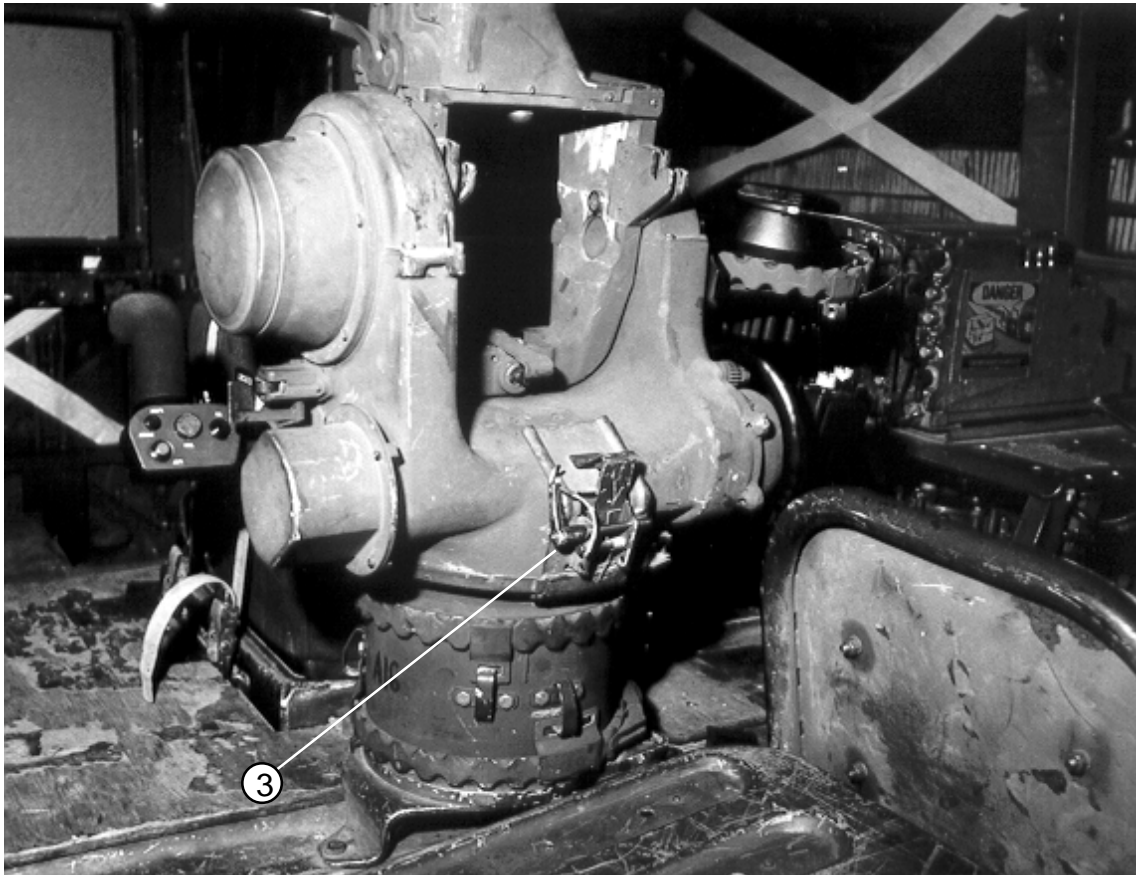
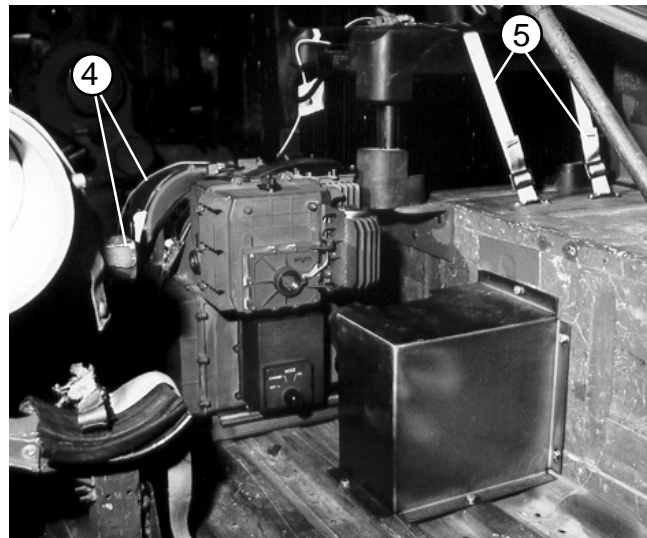
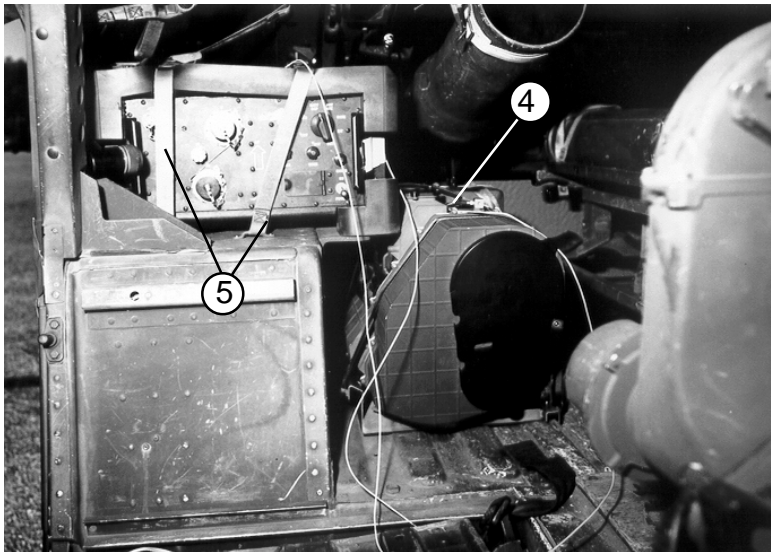

Figure 5-1. ITAS components rigged in truck



- ③ Position the TU in its mounting bracket and secure it with the clips provided.

Figure 5-1. ITAS components rigged in truck (continued)



- ④ Position the TAS into its mounting bracket, being sure that the biocular subassembly fits into its protective housing. Secure the TAS with the two straps provided.
- ⑤ Place the rubber mounts on the BPS. Position it on its mounting bracket, and secure it with the two straps provided.

Figure 5-1. ITAS components rigged in truck (continued)

CHAPTER 6

RIGGING M966, M1036, AND M1121 TOW CARRIERS FOR LOW-VELOCITY AIRDROP ON A TYPE V PLATFORM

Description of Load

6-1. The unrigged M966 TOW carrier (Figure 6-1) is described in FM 10-517/TO 13C7-1-111, Chapter 1. The truck is rigged on a 16-foot, type V airdrop platform for low-velocity airdrop. An accompanying load weighing a minimum of 800 pounds and a maximum of 2,000 pounds must be rigged in the truck. The load requires two G-11 cargo parachutes. The M1036 is the same truck with the addition of a winch, and is rigged the same as the M966. The M1121 is a heavier version of the TOW carrier, but is rigged in the same way as the M966 and M1036.

Preparing Platform

6-2. Prepare a 16-foot, type V airdrop platform according to TM 10-1670-268-20&P/TO 13C7-52-22. Install four tandem links and 18 load tie-down clevises according to FM 10-500-2/TO 13C7-1-5, and as shown in FM 10-517/TO 13C7-1-111, Figure 2-2.

**NOTES: 1. You will need FM 10-517/TO 13C7-1-111 to rig this load.
2. The nose bumper may or may not be installed.
3. Measurements given in this chapter are from the front edge of the platform, NOT from the front edge of the nose bumper.**



Figure 6-1. M966 TOW carrier

Preparing and Positioning Honeycomb Stacks

6-3. Build the honeycomb stacks as shown in FM 10-517/TO 13C7-1-111, Figures 2-3 and 2-4. Position the stacks on the platform as shown in FM 10-517/TO 13C7-1-111, Figure 2-5.

Preparing Truck

6-4. Prepare the truck as described in FM 10-517/TO 13C7-1-111, Paragraphs 2-4a through e, g, and h, and as shown in Figures 2-6 and 2-7, 2-8 (omit steps 1 and 3), 2-9, 2-11, and 2-12. Use the closed-body preparation procedures given in FM 10-517/TO 13C7-1-111, Figures 3-2 and 3-3.

Stowing Accompanying Load and Securing Doors

6-5. Prepare and stow the TOW equipment as shown in Figure 6-2 below. Secure the hatch cover as shown in FM 10-517/TO 13C7-1-111, Figure 3-4, step 11.

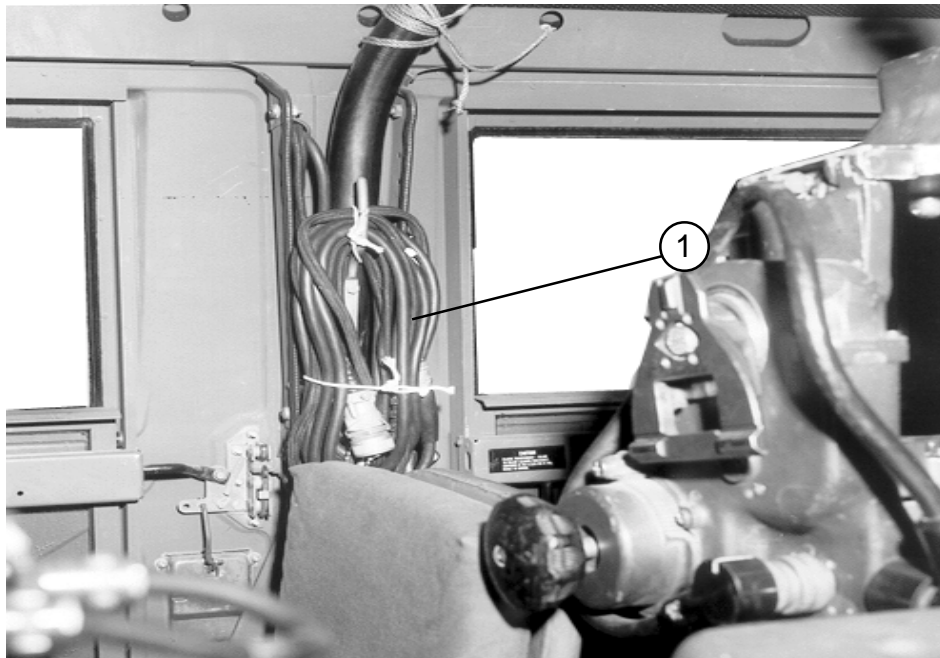

① Disconnect the TOW system power cables, roll them, and tie them with type III nylon cord to convenient places in the truck.

Figure 6-2. TOW Equipment Prepared and Stowed

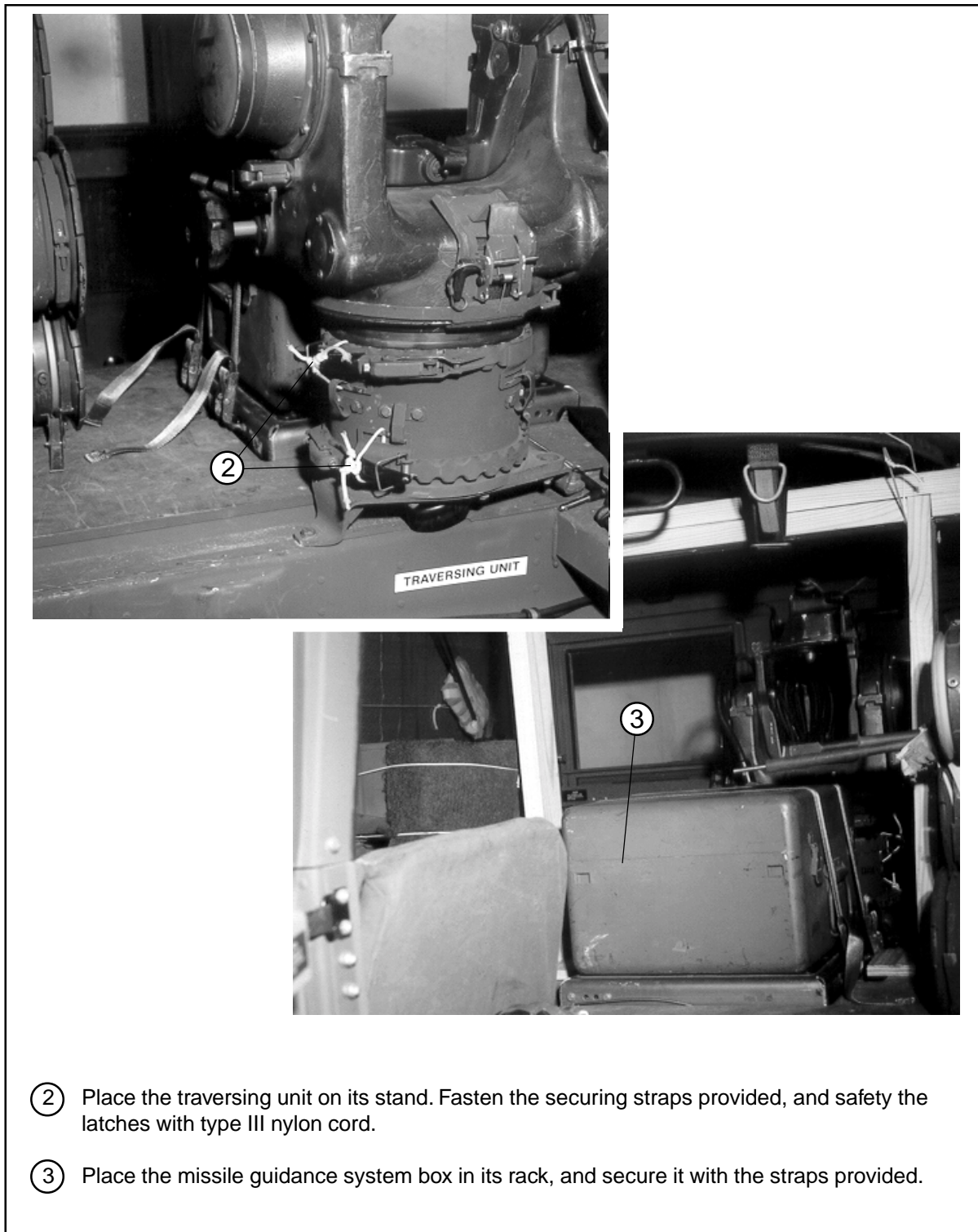

- ② Place the traversing unit on its stand. Fasten the securing straps provided, and safety the latches with type III nylon cord.
- ③ Place the missile guidance system box in its rack, and secure it with the straps provided.

Figure 6-2. TOW Equipment Prepared and Stowed (continued)



⑥

⑦

- ④ Place the boresight collimator on the shelf in the right rear part of the truck. Secure the collimator with the retainer straps.
- ⑤ Place the infrared nightsight set on the shelf in the right rear part of the truck next to the boresight collimator. Secure the nightsight set with the retainer straps.
- ⑥ Place the nightsight battery set on the floor in the right rear part of the truck. Secure the battery set with the retainer straps.
- ⑦ Place the battery power conditioner on the floor in the right rear part of the truck. Secure the battery power conditioner with the retainer straps.

Note: Pad the equipment shown above, as necessary, with cellulose wadding to prevent the equipment from rubbing against the body of the truck.

Figure 6-2. TOW Equipment Prepared and Stowed (continued)

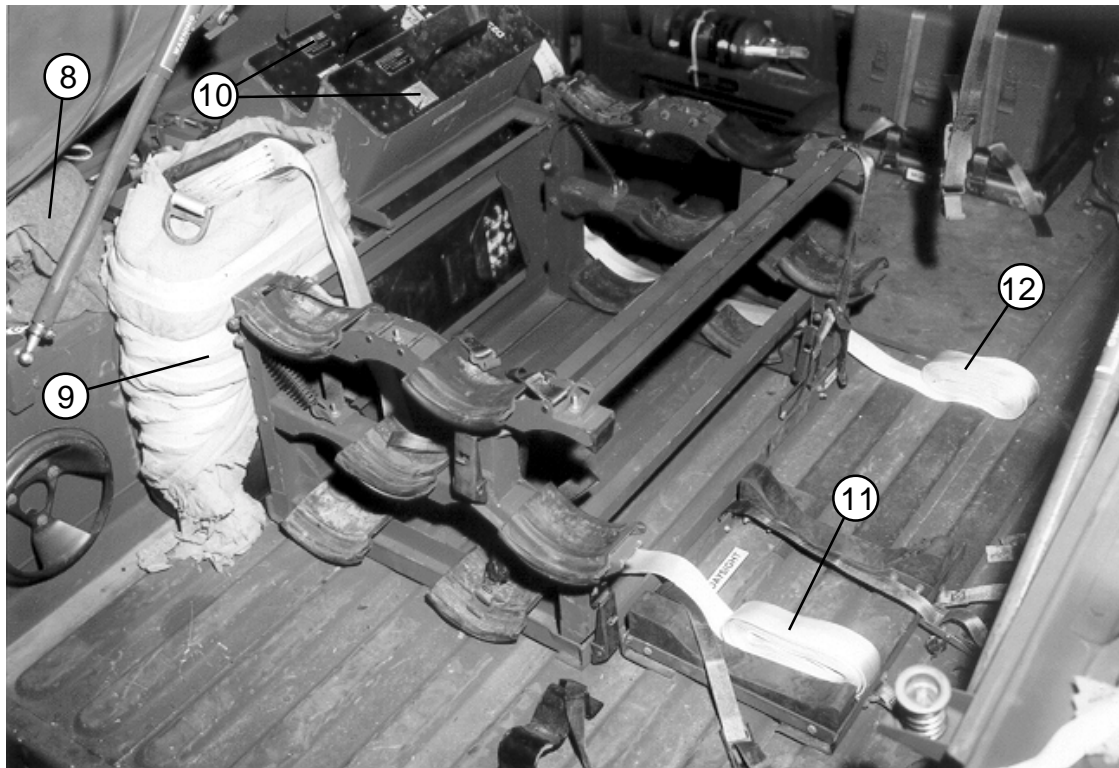

- ⑧ Place the highway emergency kit in the left rear part of the truck. Tie the kit in place with type III nylon cord.
- ⑨ Pad the M13 decontamination apparatus with felt or cellulose wadding. Tape the padding in place. Place the decontamination apparatus in its rack, and fasten the retainer straps.
- ⑩ Place the missile guidance system battery packs in their racks. Secure them in place with their fasteners.
- ⑪ Position a 15-foot lashing under the rear of the TOW missile rack.
- ⑫ Position a 15-foot lashing under the front of the TOW missile rack, and in front of the rack support.

Figure 6-2. TOW Equipment Prepared and Stowed (continued)

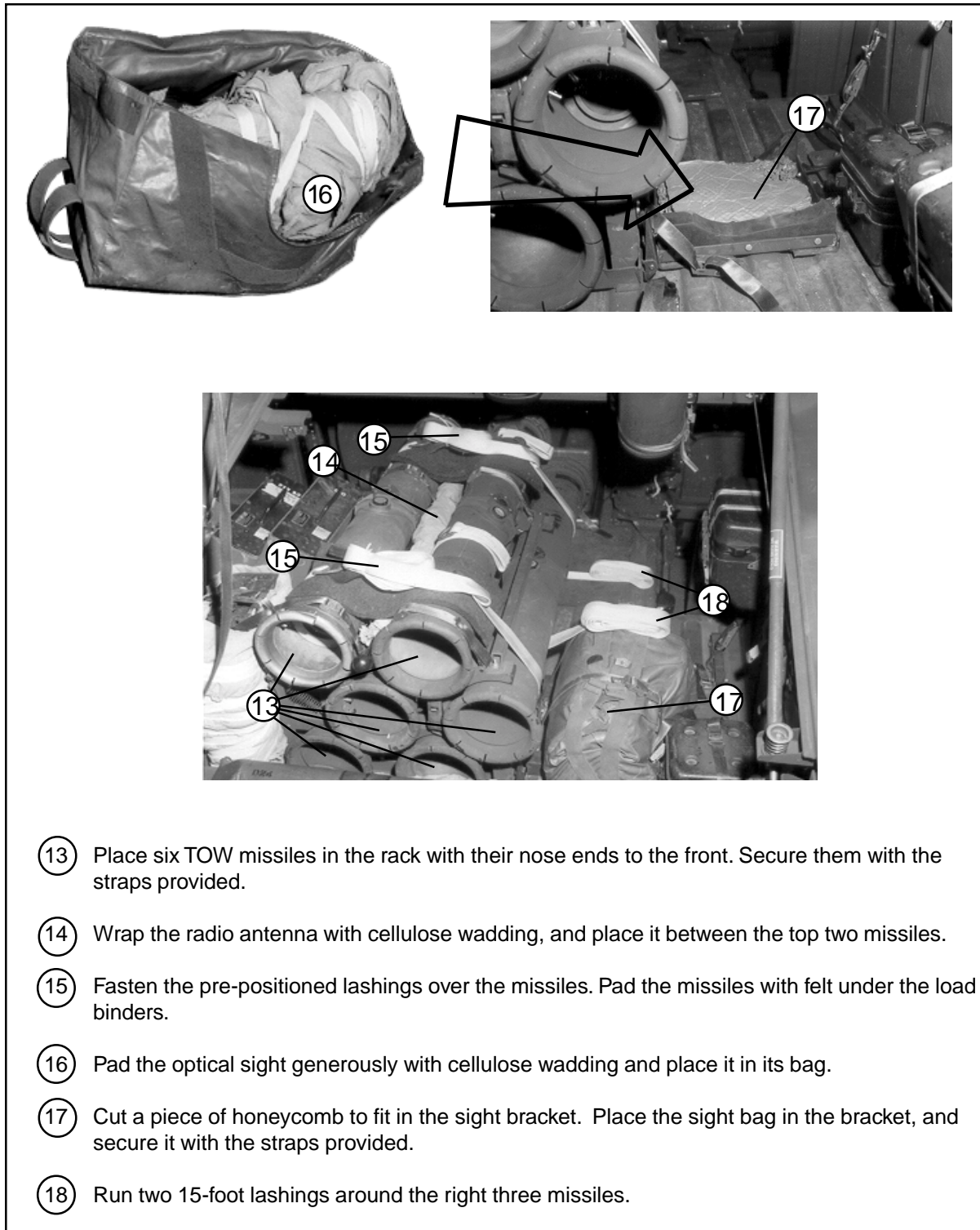

- ⑬ Place six TOW missiles in the rack with their nose ends to the front. Secure them with the straps provided.
- ⑭ Wrap the radio antenna with cellulose wadding, and place it between the top two missiles.
- ⑮ Fasten the pre-positioned lashings over the missiles. Pad the missiles with felt under the load binders.
- ⑯ Pad the optical sight generously with cellulose wadding and place it in its bag.
- ⑰ Cut a piece of honeycomb to fit in the sight bracket. Place the sight bag in the bracket, and secure it with the straps provided.
- ⑱ Run two 15-foot lashings around the right three missiles.

Figure 6-2. TOW Equipment Prepared and Stowed (continued)

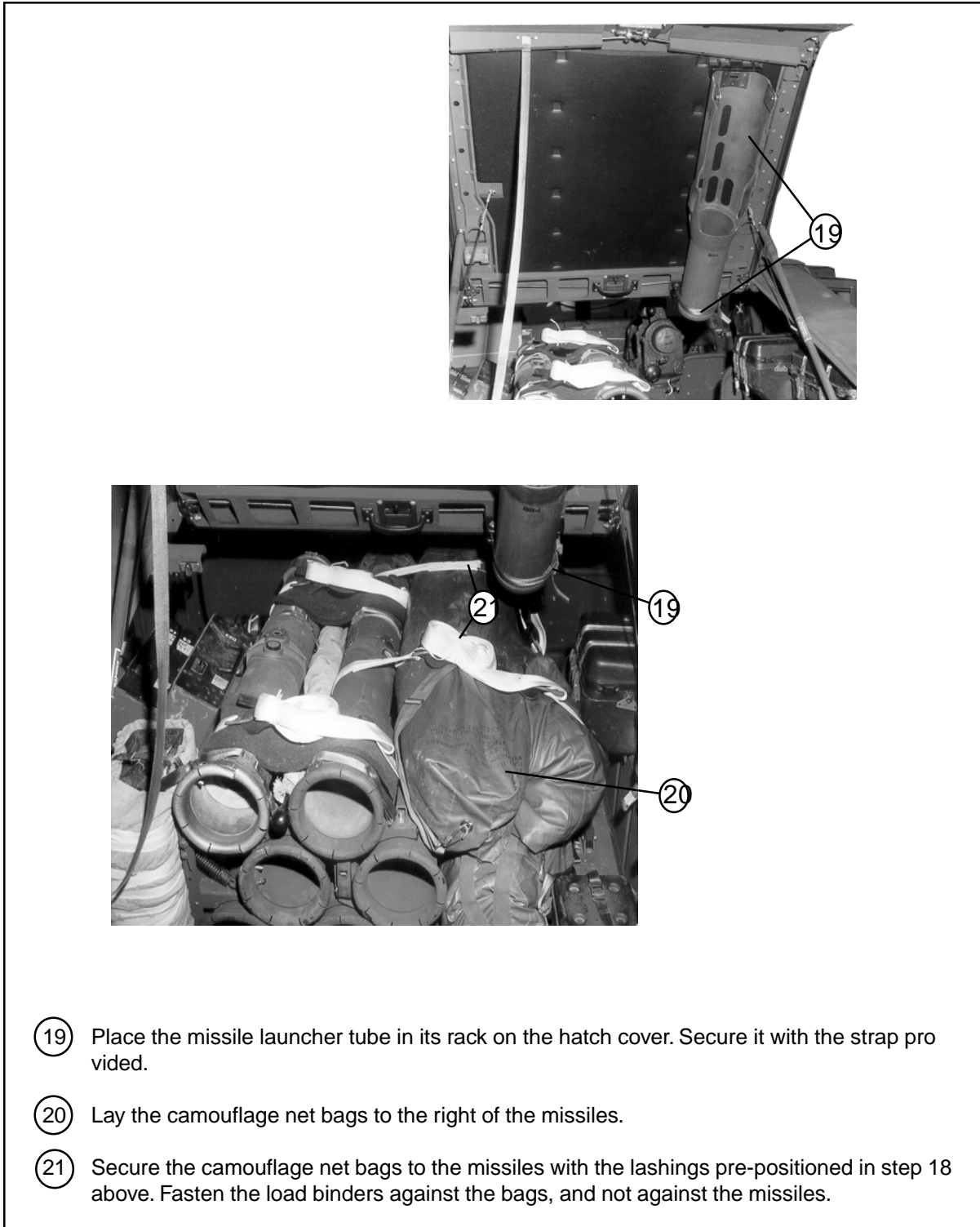
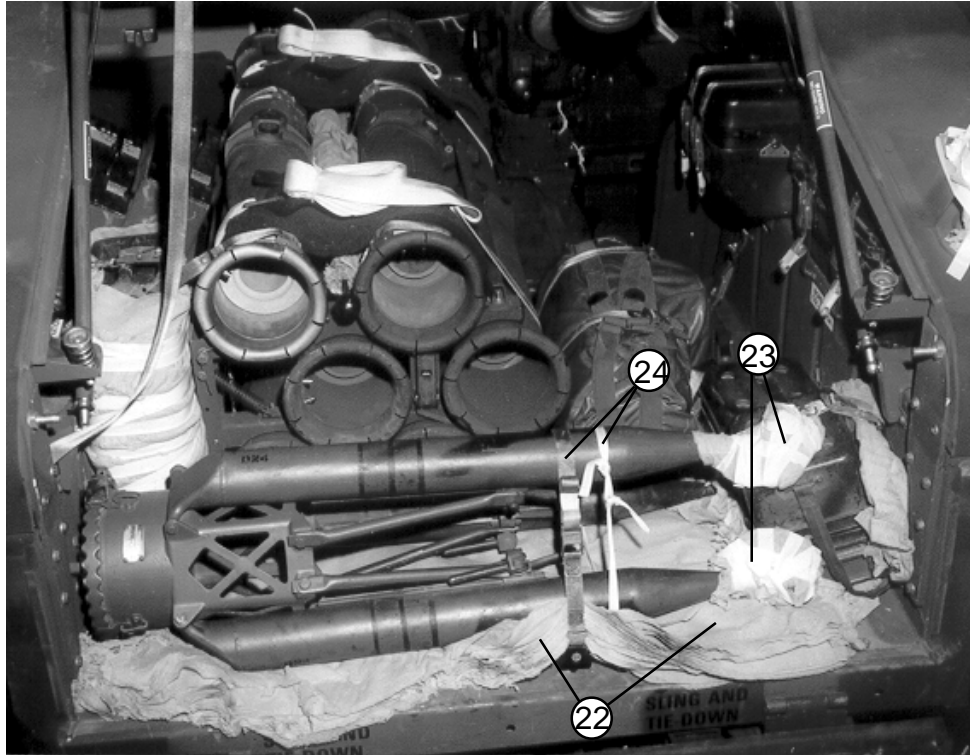

Figure 6-2. TOW Equipment Prepared and Stowed (continued)



- ②② Pad the tripod storage area with cellulose wadding.
- ②③ Place the tripod in its storage rack. Pad the legs with cellulose wadding where they touch the battery power conditioner.
- ②④ Secure the tripod in place with the retainer strap and a length of 1/2-inch tubular nylon webbing.

Figure 6-2. TOW Equipment Prepared and Stowed (continued)

Lifting and Positioning Truck and Installing Drive-Off Aids

6-6. If drive-off aids are to be used, install them on the platform as shown in FM 10-517/TO 13C7-1-111, Figure 2-16. Install lifting slings on the truck and position the truck on the honeycomb stacks as shown in FM 10-517/TO 13C7-1-111, Figure 2-17. Install the drive-off aids to the rear wheels of the truck as shown in FM 10-517/TO 13C7-1-111, Figure 2-18.

Lashing Truck

6-7. Lash the truck to the platform with fifteen 15-foot tie-down assemblies as shown in FM 10-517/TO 13C7-1-111, Figures 2-19 and 2-20, and according to FM 10-500-2/TO 13C7-1-5.

Installing and Safetying Suspension Slings

6-8. Install and safety four 16-foot (2-loop), type XXVI nylon suspension slings as shown in FM 10-517/TO 13C7-1-111, Figure 3-5.

Stowing Cargo Parachutes

6-9. Stow two G-11 cargo parachutes on the load according to FM 10-500-2/TO 13C7-1-5, and as shown in FM 10-517/TO 13C7-1-111, Figure 2-22.

Installing Parachute Release

6-10. Prepare and install an M-1 cargo parachute release according to FM 10-500-2/TO 13C7-1-5, and as shown in FM 10-517/TO 13C7-1-111, Figure 3-6.

Installing Extraction System

6-11. Install the EFTC extraction system according to FM 10-500-2/TO 13C7-1-5, and as shown in FM 10-517/TO 13C7-1-111, Figure 2-24.

Installing Provisions for Emergency Restraints

6-12. Install provisions for emergency restraints according to FM 10-500-2/TO 13C7-1-5.

Placing Extraction Parachute

6-13. Select the extraction parachute and extraction line needed, using the extraction line requirements table in FM 10-500-2/TO 13C7-1-5. Rig the extraction line in a line bag according to TM 10-1670-286-20/TO 13C5-41. Place the extraction parachute and extraction line on the load for installation in the air craft.

Marking Rigged Load

6-14. Mark the rigged load according to FM 10-500-2/TO 13C7-1-5, and as shown in Figure 6-3. Complete Shipper's Declaration for Dangerous Goods. If the load varies from the one shown, the weight, height, CB, and parachute requirements must be recomputed.

Equipment Required

6-15. Use the equipment listed in Table 6-1 to rig this load. The equipment for rigging the accompanying load is included in Table 6-1.

CAUTION: Make the final rigger inspection required by FM 10-500-2/ TO 13C7-1-5 before the load leaves the rigging site.

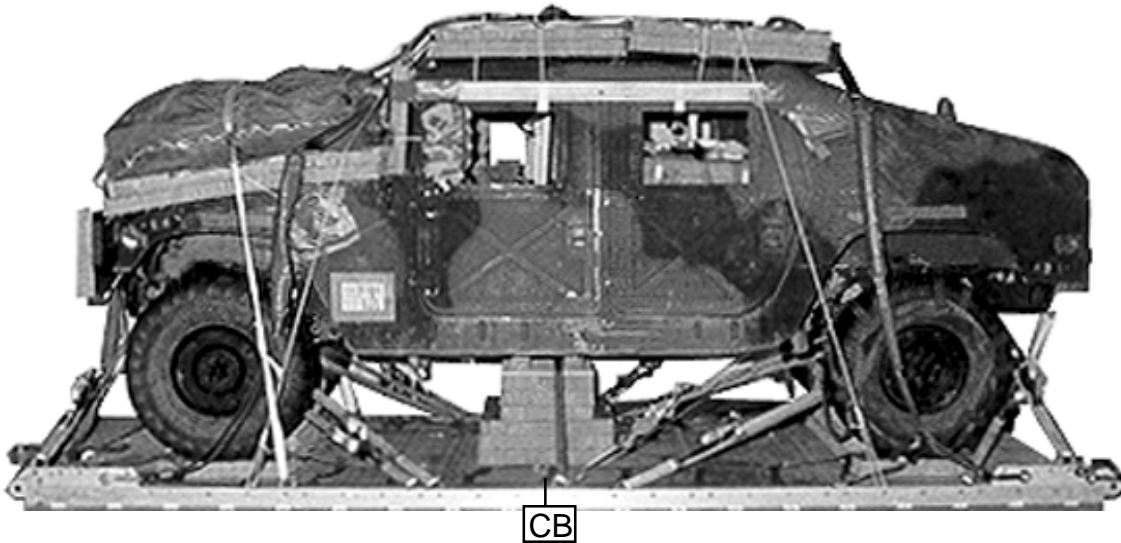

RIGGED LOAD DATA

Weight: Load shown.....	8,810 pounds
Maximum load allowed.....	10,500 pounds
Height (with two G-11 parachutes).....	91 inches
Width.....	108 inches
Length.....	215 inches
Overhang: Front.....	0 inches
Rear.....	18 inches
CB (from front edge of platform).....	102 inches

Figure 4-3. M966 TOW carrier rigged for low-velocity airdrop

Table 6-1. Equipment required for rigging the M966 TOW carrier for low-velocity airdrop

National Stock Number	Item	Quantity
8040-00-273-8713	Adhesive, paste, 1-gal	As required
4030-00-090-5354	Clevis, suspension, 1-in (large)	8
4020-00-240-2146	Cord, nylon, type III, 550-lb	As required
1670-00-434-5785	Coupling, airdrop, extraction force transfer with cable, 16-ft	1
	Cover:	
1670-00-360-0328	Clevis, large	1
1670-00-360-0329	Link, type IV	3
8135-00-664-6958	Cushioning material, packaging, cellulose wadding	As required
8305-00-958-3685	Felt, 1/2-in thick	As required
1670-01-183-2678	Leaf, extraction line (line bag)	2
	Line, drogue (for C-17)	
1670-01-064-4452	60-ft (1-loop), type XXVI	1
	Line, extraction:	
1670-01-062-6313	60-ft (3-loop), type XXVI (for C-130)(Use w/ 140-ft for C-5)	1
1670-01-107-7651	140-ft (3-loop), type XXVI (for C-141B,C-5, or C-17)	1
	Link assembly:	
1670-00-783-5988	Type IV	3
	Two-point, 3/4-in	(1)
5306-00-435-8994	Bolt, 1-in diam, 4-in long	2
5310-00-232-5165	Nut, 1-in, hexagonal	2
1670-00-003-1953	Plate, side, 3 3/4-in	2
5365-00-007-3414	Spacer, large	2
	Lumber:	
5510-00-220-6146	2- by 4-in	As required
5510-00-220-6448	2- by 6-in	As required
5510-00-220-6274	4- by 4-in	As required
5315-00-010-4659	Nail, steel wire, 8d	As required

Table 6-1. Equipment required for rigging the M966 TOW carrier for low-velocity airdrop (continued)

National Stock Number	Item	Quantity
1670-00-753-3928	Pad, energy-dissipating (honeycomb) 3- by 36- by 96-in	11 sheets
1670-01-016-7841	Parachute: Cargo: G-11B	2
1670-01-063-3716	Cargo extraction: 22-ft	1
1670-01-063-3715	Drogue (for C-17) 15-ft	1
1670-01-353-8425	Platform, airdrop, type V, 16-ft Bracket assembly, coupling	(1)
1670-01-162-2372	Clevis assembly, type V	(20)
1670-01-354-8424	Extraction bracket assembly	(1)
1670-01-162-2381	Tandem link assembly (Multipurpose link)	(4)
5530-00-128-4981	Plywood, 3/4-in	3 sheets
1670-01-097-8816	Release, cargo parachute, M-1	1
1670-01-063-7761	Sling, cargo, airdrop For suspension: 16-ft (2-loop), type XXVI nylon webbing	4
1670-01-062-6304	For lifting: 9-ft (2-loop), type XXVI nylon webbing	2
1670-01-062-6303	12-ft (2-loop), type XXVI nylon webbing	2
1670-01-062-6304	For deployment: 9-ft (2-loop), type XXVI nylon webbing	1
1670-01-062-6302	For riser extension: 20-ft (2-loop), type XXVI nylon webbing	2
5340-00-040-8219	Strap, parachute release, multi-cut, comes w/ 3 knives	2
7510-00-266-5016	Tape, adhesive, 2-in	As required
1670-00-937-0271	Tie-down assembly, 15-foot	27
1670-00-431-8486	Vehicle drive-off aids	1
8305-00-268-2411	Webbing: Cotton, 1/4-in, type I	As required
8305-00-082-5752	Nylon, tubular, 1/2-in	As required
8305-00-263-3591	Type VIII	As required

GLOSSARY

ACB	attitude control bar
AD	airdrop
AFB	Air Force base
AFJMAN	Air Force Joint Manual
AFR	Air Force regulation
AFTO	Air Force technical order
ALC	Airlift Logistics Center
attn	attention
BPS	battery power source
C	change
cap	capacity
CB	center of balance
chap	chapter
d	penny
DA	Department of the Army
DC	District of Columbia
DD	Department of Defense
diam	diameter
EFTC	extraction force transfer coupling
fig	figure
FCS	fire control subsystem
FM	field manual
ft	foot/feet
gal	gallon
HQ	headquarters
HMMWV	high-mobility, multipurpose, wheeled vehicle
in	inch
ITAS	improved target acquisition system
JAI	joint airdrop inspector
lb	pound
LV	low-velocity
MCRP	Marine Corps Reference Publication
mm	millimeter
NSN	national stock number
OVE	on-vehicular equipment
TAS	target acquisition subsystem
TM	technical manual
TO	technical order
TOW	tube launched, optically-tracked, wire-guided
TRADOC	US Army Training and Doctrine Command
TU	traversing unit
US	United States
w	with
yd	yard

REFERENCES

- AFR 55-40/AR 59-4. Joint Airdrop Inspection Records, Malfunction Investigations and Activity Reporting. 27 November 1984.
- *AFJMAN 24-204/TM 38-250. Preparing Hazardous Materials for Military Air Shipments. 25 November 1994.
- FM 10-500-2/TO 13C7-1-5. Airdrop of Supplies and Equipment: Rigging Airdrop Platforms. 1 November 1990.
- FM 10-500-3/TO 13C7-1-11. Airdrop of Supplies and Equipment: Rigging Containers. 16 October 1996.
- FM 10-500-53/TO 13C7-18-41. Airdrop of Supplies and Equipment: Rigging Ammunition. 1 March 1996.
- TM 9-2320-280-10/TO 36A-12-1A-2091-1/TM 2320-10/6. Operator's Manual for Truck, 1 1/4-ton. April 1985
- TM 10-1670-268-20&P/TO 13C7-52-22. Organizational Maintenance Manual With Repair Parts and Special Tools List: Type V Airdrop Platform. 1 June 1986.
- TM 10-1670-276-23&P/TO 13C5-29-2. Unit and Intermediate Direct Support (DS) Maintenance Manual (Including Repair Parts and Special Tools List) for Parachute, Cargo-Type: 26-foot Diameter, High-Velocity Cargo Parachute. 28 September 1990.
- TM 10-1670-278-23&P/TO 13C5-26-2/NAVAIR 13-1-27/TM 01109C-23&P/1. Unit and Intermediate DS Maintenance Manual Including Repair Parts and Special Tools List for Parachute, Cargo Type, 15-ft Diam, Cargo Extraction. 6 November 1989.
- TM 10-1670-279-23&P/TO 13C5-27-2/NAVAIR 13-1-28. Unit and Intermediate DS Maintenance Manual Including Repair Parts and Special Tools List for Parachute, Cargo Type, 22-ft Diam, Cargo Extraction. 30 August 1989.
- TM 10-1670-280-23&P/TO 13C5-31-2/NAVAIR 13-1-31. Unit and Intermediate DS Maintenance Manual Including Repair Parts and Special Tools List for Parachute, Cargo Type, G-11A, G-11B, and G-11C. 5 August 1991.
- TM 10-1670-281-23&P/TO 13C5-32-2. Unit and Intermediate DS Maintenance Manual Including Repair Parts and Special Tools List for Parachute, Cargo Type: 64-foot Diameter, Model G-12D and Model G-12E. 12 October 1990.

TM 10-1670-282-23&P/TO 13C5-30-2. Unit and Intermediate DS Maintenance Manual Including Repair Parts and Special Tools List for Parachute, Cargo Type: 34-foot Diameter, Model G-14, Low-Velocity Cargo Parachute. 12 October 1990.

TM 10-1670-286-20/TO 13C5-2-41. Unit Maintenance Manual for Sling/Extraction Line Panel (Including Stowing Procedures). 1 April 1986.

TM 10-1670-298-20&P. Unit Maintenance Manual (Including Repair Parts and Special Tools List) Container Delivery System. 15 September 1995.

AFTO Form 22. Technical Order Publication Improvement Report

DA Form 2028. Recommended Changes to Publication and Blank Forms. February 1974.

* Shipper's Declaration for Dangerous Goods. Locally procured form

*AFJMAN24-204/TM 38-250 has superseded AFR 71-4/TM 38-250 (15 January 1988). This revision reflects this change.

* Shipper's Declaration for Dangerous Goods has superseded DD Form 1387-2 (February 1982.) This revision reflects this change.

**FM 10-500-29
TO 13C7-10-171
14 APRIL 2000**

By Order of the Secretary of the Army:

ERIC K. SHINSEKI
General, United States Army
Chief of Staff

Official:



Handwritten signature of Joel B. Hudson in cursive script.

JOEL B. HUDSON
*Administrative Assistant to the
Secretary of the Army*
005602

DISTRIBUTION:

Active Army, Army National Guard, and U.S. Army Reserve: To be distributed in accordance with the initial distribution number 115784, requirements for FM 10-500-29.

MICHAEL E. RYAN
General, USAF
Chief of Staff

GEORGE T. BABBITT
General, USAF
Commander, AFMC